

LOT 1 BRELLINGER 3RD ADDN SUBD

COLUMBIA IL 62298
Site Address: 000367 BRELLINGER ST

BLDG # 1
 Style/Stories 1.0 One Story
 Quality/Design C C-Average
 Building Use 0100 Single Fami
 Exterior Wall M Masonry 1.0
 WALL % 100 100%
 Exterior Wall 1
 WALL 1% 000 N/A
 Crawl Sp. Adj
 Slab Adjustment
 Basement
 Combination
 Attic Area
 Heat/AC Adj AC Central Air
 Comb Ht/AC Adj
 Fireplace 03 C-Fireplace
 Extra Fireplace 00 N/A
 Res Fixtures 0013 13 Fixtures
 Garage M Masonry Gar
 Integral Garage
 Remodeling Adj 01 No Remodeli
 Actual Year Blt 2013
 Effect Year Blt 2013
 Cond/Desir/Util A
 Township Multpl 04 TOWNSHIP #0
 Funct. Obs. % 000000
 Economic Obs. % 000000
 Observed Cond % 000000
 Obs. Cond. Code
 Combination A
 Comb A Ht/AC
 Unfin Low/Level
 Full Basement F Full Baseme
 # Of Bedrooms 03 Three Bedro
 Sq.Ft.Grnd Area 3259

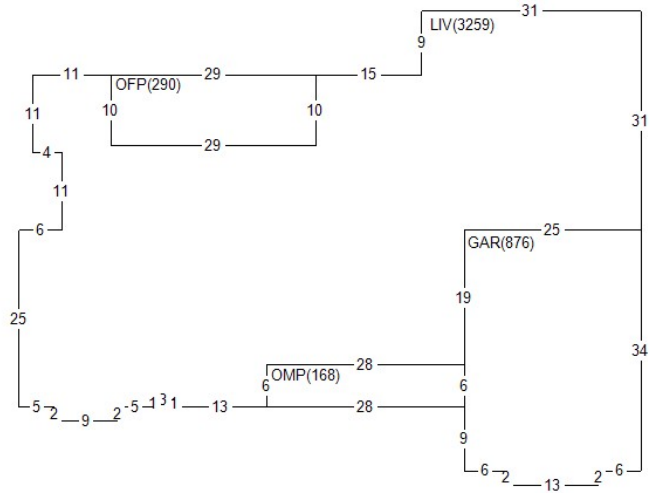

Land Value 123,150
 Misc Value 62,210
 Bldg Value 670,710
 Total Value 856,070
 Value By CAMA

RCN 706,007
 Pct Good 0.9500
 Obsol/Observed 0.0000
 Building Value 670,710

DOCUMENT # DATE QS SALE PRICE
 362509 0113 Q 133,000

PERMIT NO TYPE DATE AMOUNT
 BP-13-186 08 1113
 BP-13-185 10 1113
 BP-13-023 00 1113
 Appraiser DG D. Goff
 Apr Date 06/24/20
 Use Code 0040 Imp Res
 NBHD 411.10 BRELLINGER 1.0
 L100 M100 B260

AREA	FLAT	EFF% E/AREA	ACT% A/AREA	EA/AA HEATED
LIV	3259	1.00	3259 1.00	3259 3259
OFF	290	1.00	290 1.00	290 290
OMP	168	1.00	168 1.00	168 168
GAR	876	1.00	876 1.00	876 876
CONDR	4212	1.00	4212 1.00	4212 4212
POOL	738	1.00	738 1.00	738 738
PTO	1590	1.00	1590 1.00	1590 1590

MISC BLDG CODE	DESC	LENGTH	WIDTH	UNITS	ADJ PRICE	EYB DT PCT	ADJUSTMENT	VALUE
1 1 OMP	Open Masonry Por	6.00	28.00	168.00	31.38	2013 A 5.00	1.00	5,010
2 1 OFF	Open Frame Porch	10.00	29.00	290.00	23.02	2013 A 5.00	1.00	6,340
3 1 CONDR	Concrete Drivewa	.00	.00	4212.00	3.65	2013 A 5.00	1.00	14,610
4 1 POOLCNC	Concrete Res Poo	41.00	18.00	738.00	43.30	2014 A 4.00	1.00	30,680
5 1 PTO	Concrete Patio	.00	.00	1590.00	3.65	2014 A 4.00	1.00	5,570

LAND LUSE DESC	ZONING	UNITS TP	PRICE	ADJUSTMENT	CODE/FACTOR	VALUE
1 0412 COLUMBIA LAND #3	CR2	40510.80 S	3.04	TW 1.00	.00 .00 .00	123,150