

LOT 10 BRELLINGER 3RD ADDN SUBD

COLUMBIA IL 62236  
Site Address: 000301 BRELLINGER ST

BLDG # 1  
 Style/Stories 2.0 2 Story  
 Quality/Design C C-Average  
 Building Use 0100 Single Fami  
 Exterior Wall M Masonry 2.0  
 WALL % 060 060%  
 Exterior Wall 1 F Frame  
 WALL 1% 040 040%  
 Crawl Sp. Adj C Crawl  
 Slab Adjustment  
 Basement RC C-Rec Room  
 Combination M1 Masonry/1.0  
 Attic Area  
 Heat/AC Adj AC Central Air  
 Comb Ht/AC Adj AC1 Cent AC Cmb  
 Fireplace 31 DirectVent  
 Extra Fireplace 00 N/A  
 Res Fixtures 0029 29 Fixtures  
 Garage M Masonry Gar  
 Integral Garage  
 Remodeling Adj 01 No Remodeli  
 Actual Year Blt 2014  
 Effect Year Blt 2014  
 Cond/Desir/Util A Res CDU - A  
 Township Multpl 04 TOWNSHIP #0  
 Funct. Obs. % 000000  
 Economic Obs. % 000000  
 Observed Cond % 000000  
 Obs. Cond. Code  
 Combination A  
 Comb A Ht/AC  
 Unfin Low/Level  
 Full Basement F Full Baseme  
 # Of Bedrooms 05 Five Bedroo  
 Sq.Ft.Grnd Area 3643

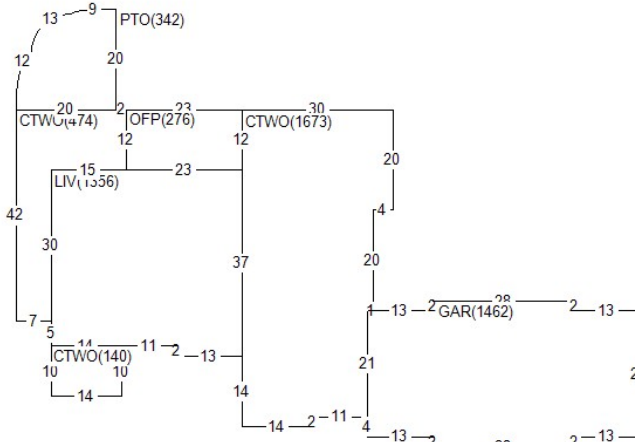

Land Value 126,520  
 Misc Value 59,850  
 Bldg Value 792,190  
 Total Value 978,560  
 Value By CAMA

RCN 825,196  
 Pct Good 0.9600  
 Obsol/Observed 0.0000  
 Building Value 792,190

DOCUMENT #	DATE	QS	SALE PRICE
420469	1021	Q	915,000
365953	0613	Q	136,800

PERMIT NO	TYPE	DATE	AMOUNT
BP-14-096	10	0714	
BP-13-121-	00	0614	
BP-13-121	01	0813	

Appraiser AS A. Schwar  
 Appr Date 11/01/21  
 Use Code 0040 Imp Res  
 NBHD 411.20 BRELLINGER 2.0  
 L100 M100 B216

AREA	FLAT	EFF% E/AREA	ACT% A/AREA	EA/AA	HEATED
LIV	1356	1.00	1356	1.00	1356
CTWO	2287	1.00	2287	1.00	2287
OFFP	276	1.00	276	1.00	276
PTO	1480	1.00	1480	1.00	1480
GAR	1462	1.00	1462	1.00	1462
CRWL	55	1.00	55	1.00	55
CONDR	3631	1.00	3631	1.00	3631
POOL	495	1.00	495	1.00	495
BSMR	1700	1.00	1700	1.00	1700

MISC BLDG CODE	DESC	LENGTH	WIDTH	UNITS	ADJ PRICE	EYB DT	PCT	ADJUSTMENT	VALUE
1	1 OFFP2	12.00	23.00	276.00	34.95	2014 A	4.00	1.00	9,260
2	1 PTO	.00	.00	342.00	3.65	2014 A	4.00	1.00	1,200
3	1 CONDR	.00	.00	3631.00	3.65	2014 A	4.00	1.00	12,720
4	1 BRVEN	.00	.00	621.00	14.65	2014 A	4.00	1.00	8,730
5	1 POOLCNC	33.00	15.00	495.00	50.40	2014 A	4.00	1.00	23,950
6	1 PTO	.00	.00	1138.00	3.65	2014 A	4.00	1.00	3,990
LAND LUSE DESC	ZONING	UNITS TP	PRICE	ADJUSTMENT	CODE/FACTOR	ADJUSTMENT	VALUE		
1 0412 COLUMBIA LAND #3	CR2	61419.60 S	2.06	TW 1.00	.00	.00	126,520		