

LOT 9 BRELLINGER 3RD ADDN SUBD

COLUMBIA IL 62236  
Site Address: 000307 BRELLINGER ST

BLDG # 1  
 Style/Stories 2.0 2 Story  
 Quality/Design C C-Average  
 Building Use 0100 Single Fami  
 Exterior Wall M Masonry 2.0  
 WALL % 100 100%  
 Exterior Wall 1  
 WALL 1% 000 N/A  
 Crawl Sp. Adj  
 Slab Adjustment  
 Basement  
 Combination M1 Masonry/1.0  
 Attic Area FA Finished  
 Heat/AC Adj AC Central Air  
 Comb Ht/AC Adj AC1 Cent AC Cmb  
 Fireplace 03 C-Fireplace  
 Extra Fireplace 33 2-DirectVen  
 Res Fixtures 0019 19 Fixtures  
 Garage M Masonry Gar  
 Integral Garage  
 Remodeling Adj 01 No Remodeli  
 Actual Year Blt 2021  
 Effect Year Blt 2021  
 Cond/Desir/Util A Res CDU - A  
 Township Multpl 04 TOWNSHIP #0  
 Funct. Obs. % 000000  
 Economic Obs. % 000000  
 Observed Cond % 000000  
 Obs. Cond. Code  
 Combination A  
 Comb A Ht/AC  
 Unfin Low/Level  
 Full Basement F Full Baseme  
 # Of Bedrooms 04 Four Bedroo  
 Sq.Ft.Grd Area 2924

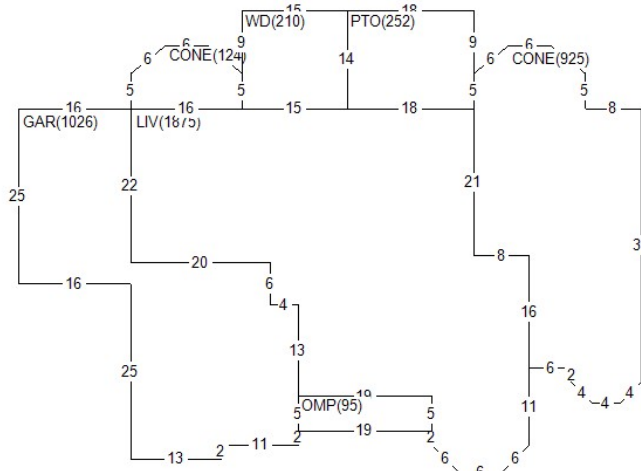

Land Value 125,580  
 Misc Value 39,560  
 Bldg Value 762,000  
 Total Value 927,140  
 Value By CAMA

RCN 769,694  
 Pct Good 0.9900  
 Obsol/Observed 0.0000  
 Building Value 762,000

DOCUMENT #	DATE	QS	SALE PRICE
411696	1020	Q	97,500
388778	0317	Q	102,638

PERMIT NO	TYPE	DATE	AMOUNT
22-7464	00	0522	
21-6690	01	0521	

Appraiser KK K. Kenned  
 Appr Date 01/12/24  
 Use Code 0040 Imp Res  
 NBHD 411.20 BRELLINGER 2.0  
 L100 M100 B216

AREA	FLAT	EFF%	E/AREA	ACT%	A/AREA	EA/AA	HEATED
LIV	1875	1.00	1875	1.00	1875	1875	1875
CONE	1049	1.00	1049	1.00	1049	1049	
GAR	1026	1.00	1026	1.00	1026	1026	
OMP	95	1.00	95	1.00	95	95	
WD	210	1.00	210	1.00	210	210	
PTO	252	1.00	252	1.00	252	252	
FA	336	1.00	336	1.00	336	336	

MISC BLDG CODE	DESC	LENGTH	WIDTH	UNITS	ADJ PRICE	EYB DT PCT	ADJUSTMENT	VALUE
1	1 OMP	19.00	5.00	95.00	35.10	2022 A 1.00	1.00	3,300
2	1 WD	14.00	15.00	210.00	19.35	2022 A 1.00	1.00	4,020
3	1 PTO	33.00	14.00	462.00	3.65	2022 A 1.00	1.00	1,670
4	1 BRVEN	.00	.00	993.00	14.65	2022 A 1.00	1.00	14,400
5	1 CONFL	22.00	16.00	352.00	3.38	2022 A 1.00	1.00	1,180
6	1 BSMW	76.00	8.00	608.00	7.11	2022 A 1.00	1.00	4,280
LAND LUSE DESC	ZONING	UNITS	TP	PRICE	ADJUSTMENT	CODE/FACTOR	ADJUSTMENT	VALUE
1 0412 COLUMBIA LAND #3	CR2	55321.20	S	2.27	TW	1.00	.00 .00 .00	125,580

Req By: DAWN  
JOHN D & EMILY K GALLE  
307 BRELLINGER ST

MISC BLDG CODE	DESC	Site Address:	COLUMBIA	IL 62236	BRELLINGER	ST	LENGTH	WIDTH	UNITS	ADJ PRICE	EYB DT	PCT	ADJUSTMENT	VALUE
7 1 CONDR	Concrete Drivewa	000307					.00	.00	2965.00	3.65	2022 A	1.00	1.00	10,710