

LOT 8 BRELLINGER 3RD ADDN SUBD

COLUMBIA IL 62236
Site Address: 000313 BRELLINGER ST

BLDG # 1
 Style/Stories 1.0 One Story
 Quality/Design C C-Average
 Building Use 0100 Single Fami
 Exterior Wall M Masonry 1.0
 WALL % 070 070%
 Exterior Wall 1 F Frame
 WALL 1% 030 030%
 Crawl Sp. Adj
 Slab Adjustment
 Basement LC C-Living Qt
 Combination
 Attic Area
 Heat/AC Adj AC Central Air
 Comb Ht/AC Adj
 Fireplace 03 C-Fireplace
 Extra Fireplace 00 N/A
 Res Fixtures 0013 13 Fixtures
 Garage M Masonry Gar
 Integral Garage
 Remodeling Adj 01 No Remodeli
 Actual Year Blt 2020
 Effect Year Blt 2020
 Cond/Desir/Util A Res CDU - A
 Township Multpl 04 TOWNSHIP #0
 Funct. Obs. % 000000
 Economic Obs. % 000000
 Observed Cond % 000000
 Obs. Cond. Code
 Combination A
 Comb A Ht/AC
 Unfin Low/Level
 Full Basement F Full Baseme
 # Of Bedrooms 03 Three Bedro
 Sq.Ft.Grđ Area 3303

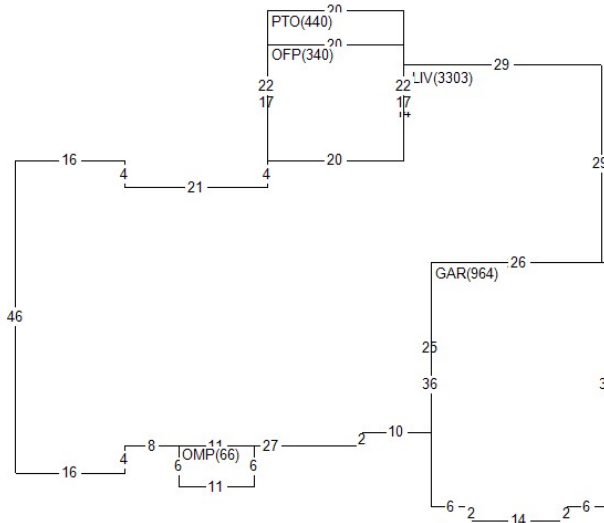

Land Value 124,930
 Misc Value 33,210
 Bldg Value 712,630
 Total Value 870,770
 Value By CAMA

RCN 719,826
 Pct Good 0.9900
 Obsol/Observed 0.0000
 Building Value 712,630

DOCUMENT #	DATE	QS	SALE PRICE
395628	0518	Q	125,000
390014	0517	Q	119,510

PERMIT NO	TYPE	DATE	AMOUNT
4897	00	0420	
BP-19-050	01	0419	

Appraiser RM R. Mueller
 Appr Date 07/29/21
 Use Code 0040 Imp Res
 NBHD 411.10 BRELLINGER 1.0
 L100 M100 B260

AREA	FLAT	EFF%	E/AREA	ACT%	A/AREA	EA/AA	HEATED
LIV	3303	1.00	3303	1.00	3303	3303	3303
GAR	964	1.00	964	1.00	964	964	
OMP	66	1.00	66	1.00	66	66	
OFF	340	1.00	340	1.00	340	340	
PTO	440	1.00	440	1.00	440	440	
BSML	752	1.00	752	1.00	752	752	
CONDR	2386	1.00	2386	1.00	2386	2386	

MISC BLDG CODE	DESC	LENGTH	WIDTH	UNITS	ADJ PRICE	EYB DT	PCT	ADJUSTMENT	VALUE
1	1 OMP	6.00	11.00	66.00	39.06	2020 A	1.00	1.00	2,550
2	1 OFF	17.00	20.00	340.00	22.40	2020 A	1.00	1.00	7,540
3	1 PTO	22.00	20.00	440.00	3.65	2020 A	1.00	1.00	1,590
4	1 CONDR	.00	.00	2386.00	3.65	2020 A	1.00	1.00	8,620
5	1 BRVEN	.00	.00	890.00	14.65	2020 A	1.00	1.00	12,910

LAND LUSE DESC	ZONING	UNITS TP	PRICE	ADJUSTMENT	CODE/FACTOR	VALUE
1 0412 COLUMBIA LAND #3	CR2	52272.00 S	2.39	TW 1.00	.00 .00 .00	124,930