

LOT 7 BRELLINGER 3RD ADDN SUBD

319 BRELLINGER STREET

COLUMBIA IL 62236

Site Address: 000319 BRELLINGER ST

BLDG # 1
 Style/Stories 2.0 2 Story
 Quality/Design C C-Average
 Building Use 0100 Single Fami
 Exterior Wall M Masonry 2.0
 WALL % 050 050%
 Exterior Wall 1 F Frame
 WALL 1% 050 050%
 Crawl Sp. Adj C Crawl
 Slab Adjustment
 Basement
 Combination M1 Masonry/1.0
 Attic Area
 Heat/AC Adj AC Central Air
 Comb Ht/AC Adj AC1 Cent AC Cmb
 Fireplace 03 C-Fireplace
 Extra Fireplace 00 N/A
 Res Fixtures 0021 21 Fixtures
 Garage M Masonry Gar
 Integral Garage IG Integral Ga
 Remodeling Adj 01 No Remodeli
 Actual Year Blt 2017
 Effect Year Blt 2017
 Cond/Desir/Util A Res CDU - A
 Township Multpl 04 TOWNSHIP #0
 Funct. Obs. % 000000
 Economic Obs. % 000000
 Observed Cond % 000000
 Obs. Cond. Code
 Combination A MF15 Masonry/Fr
 Comb A Ht/AC AC15 Cent AC Cmb
 Unfin Low/Level
 Full Basement F Full Baseme
 # Of Bedrooms 04 Four Bedroo
 Sq.Ft.Grd Area 2613

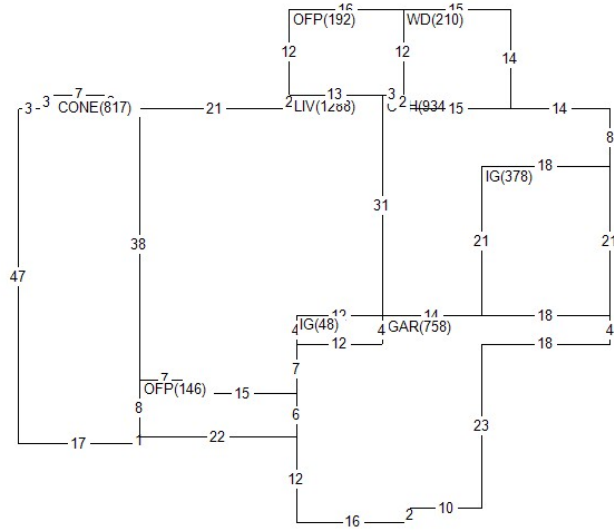

Land Value 124,130
 Misc Value 18,150
 Bldg Value 636,520
 Total Value 778,800
 Value By CAMA

RCN 649,508
 Pct Good 0.9800
 Obsol/Observed 0.0000
 Building Value 636,520

DOCUMENT # DATE QS SALE PRICE
 382177 0316 Q 124,900

PERMIT NO TYPE DATE AMOUNT
 OP-17-110 00 0617
 BP-16-193 01 1016

Appraiser DG D. Goff
 Appr Date 08/19/25
 Use Code 0040 Imp Res
 NBHD 411.20 BRELLINGER 2.0
 L100 M100 B216

AREA	FLAT	EFF% E/AREA	ACT% A/AREA	EA/AA HEATED
LIV	1288	1.00	1288 1.00	1288 1288
CONE	817	1.00	817 1.00	817 817
COH	934	1.00	934 1.00	934 934
GAR	758	1.00	758 1.00	758 758
IG	426	1.00	426 1.00	426 426
OFFP	338	1.00	338 1.00	338 338
WD	210	1.00	210 1.00	210 210
CONDR	1787	1.00	1787 1.00	1787 1787
CRWL	18	1.00	18 1.00	18 18

MISC BLDG CODE	DESC	LENGTH	WIDTH	UNITS	ADJ PRICE	EYB DT PCT	ADJUSTMENT	VALUE
1 1 CONDR	Concrete Drivewa	.00	.00	1787.00	3.65	2017 A 2.00	1.00	6,390
2 1 OFFP	Open Frame Porch	.00	.00	146.00	24.19	2017 A 2.00	1.00	3,460
3 1 OFFP	Open Frame Porch	12.00	16.00	192.00	22.97	2017 A 2.00	1.00	4,320
4 1 WD	Wood Deck	14.00	15.00	210.00	19.35	2017 A 2.00	1.00	3,980

LAND LUSE DESC	ZONING	UNITS TP	PRICE	ADJUSTMENT	CODE/FACTOR	VALUE
1 0412 COLUMBIA LAND #3	CR2	45302.40 S	2.74 TW	1.00	.00 .00	124,130