

LOT 14 BRELLINGER 3RD ADDN SUBD

COLUMBIA IL 62236

Site Address: 001521 ANTON DR

BLDG # 1  
 Style/Stories 1.0 One Story  
 Quality/Design C C-Average  
 Building Use 0100 Single Fami  
 Exterior Wall M Masonry 1.0  
 WALL % 100 100%  
 Exterior Wall 1  
 WALL 1% 000 N/A  
 Crawl Sp. Adj  
 Slab Adjustment  
 Basement LC C-Living Qt  
 Combination  
 Attic Area  
 Heat/AC Adj AC Central Air  
 Comb Ht/AC Adj  
 Fireplace 23 C-2 Fr.Pl/2  
 Extra Fireplace 31 DirectVent  
 Res Fixtures 0019 19 Fixtures  
 Garage M Masonry Gar  
 Integral Garage  
 Remodeling Adj 01 No Remodeli  
 Actual Year Blt 2013  
 Effect Year Blt 2013  
 Cond/Desir/Util A Res CDU - A  
 Township Multpl 04 TOWNSHIP #0  
 Funct. Obs. % 000000  
 Economic Obs. % 000000  
 Observed Cond % 000000  
 Obs. Cond. Code  
 Combination A  
 Comb A Ht/AC  
 Unfin Low/Level  
 Full Basement F Full Baseme  
 # Of Bedrooms 03 Three Bedro  
 Sq.Ft.Grđ Area 3512

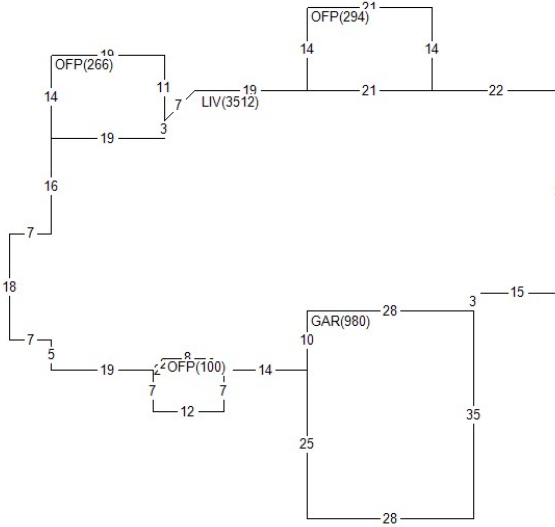

Land Value 124,410  
 Misc Value 64,750  
 Bldg Value 811,480  
 Total Value 1,000,640  
 Value By CAMA

RCN 854,194  
 Pct Good 0.9500  
 Obsol/Observed 0.0000  
 Building Value 811,480

DOCUMENT #	DATE	QS	SALE PRICE
421631	1221	U	
400699	0419	Q	650,000
357497	0712	Q	127,750
PERMIT NO	TYPE	DATE	AMOUNT
BP-13-061	08	0413	
BP-13-060	10	0413	
805	00	0313	
Appraiser	DG	D. Goff	
Apr Date		08/19/25	
Use Code	0040	Imp Res	
NBHD	411.10	BRELLINGER	1.0
		L100 M100 B260	

AREA	FLAT	EFF% E/AREA	ACT% A/AREA	EA/AA	HEATED
LIV	3512	1.00	3512	1.00	3512
GAR	980	1.00	980	1.00	980
OFF	1220	1.00	1220	1.00	1220
ASP	4081	1.00	4081	1.00	4081
CONDR	363	1.00	363	1.00	363
POOL	584	1.00	584	1.00	584
PTO	896	1.00	896	1.00	896
BSML	2663	1.00	2663	1.00	2663

MISC BLDG CODE	DESC	LENGTH	WIDTH	UNITS	ADJ PRICE	EYB DT	PCT	ADJUSTMENT	VALUE	
1	1 OFF	Open Frame Porch	.00	.00	100.00	27.00	2014 A	4.00	1.00	2,590
2	1 PTO	Concrete Patio	14.00	19.00	266.00	3.65	2014 A	4.00	1.00	930
3	1 OFF	Open Frame Porch	14.00	19.00	266.00	23.49	2014 A	4.00	1.00	6,000
4	1 PTO	Concrete Patio	14.00	21.00	294.00	3.65	2014 A	4.00	1.00	1,030
5	1 OFF	Open Frame Porch	14.00	21.00	294.00	22.95	2014 A	4.00	1.00	6,480
6	1 CONDR	Concrete Drivewa	.00	.00	363.00	3.65	2014 A	4.00	1.00	1,270
LAND LUSE DESC	ZONING	UNITS TP	PRICE	ADJUSTMENT	CODE/FACTOR	ADJUSTMENT	VALUE			
1 0412 COLUMBIA LAND #3	CR2	48787.20 S	2.55	TW	1.00	.00	.00	.00	124,410	

			COLUMBIA		IL 62236						
Site Address: 001521			ANTON		DR						
MISC	BLDG CODE	DESC	LENGTH	WIDTH	UNITS	ADJ PRICE	EYB DT	PCT	ADJUSTMENT	VALUE	
7	1 ASP	Asphalt Driveway	.00	.00	4081.00	2.85	2014 A	4.00	1.00	11,170	
8	1 POOLVNL	Vinyl Ln Res Poo	.00	.00	584.00	32.03	2014 A	4.00	1.00	17,960	
9	1 PTO	Concrete Patio	.00	.00	896.00	3.65	2014 A	4.00	1.00	3,140	
10	1 BRVEN	Brick Veneer	.00	.00	1008.00	14.65	2014 A	4.00	1.00	14,180	