

Req By: DAWN  
JEFFREY A TAYLOR TRUST &  
CATHERINE J TAYLOR TRUST  
1541 ANTON DR

LOT 17 BRELLINGER 3RD ADDN SUBD

COLUMBIA IL 62236

Site Address: 001541 ANTON DR

BLDG # 1  
 Style/Stories 1.0 One Story  
 Quality/Design C C-Average  
 Building Use 0100 Single Fami  
 Exterior Wall M Masonry 1.0  
 WALL % 060 060%  
 Exterior Wall 1 F Frame  
 WALL 1% 040 040%  
 Crawl Sp. Adj  
 Slab Adjustment  
 Basement LC C-Living Qt  
 Combination  
 Attic Area  
 Heat/AC Adj AC Central Air  
 Comb Ht/AC Adj  
 Fireplace 34 3-DirectVen  
 Extra Fireplace 00 N/A  
 Res Fixtures 0021 21 Fixtures  
 Garage M Masonry Gar  
 Integral Garage  
 Remodeling Adj 01 No Remodeli  
 Actual Year Blt 2018  
 Effect Year Blt 2018  
 Cond/Desir/Util A Res CDU - A  
 Township Multpl 04 TOWNSHIP #0  
 Funct. Obs. % 000000  
 Economic Obs. % 000000  
 Observed Cond % 000000  
 Obs. Cond. Code  
 Combination A  
 Comb A Ht/AC  
 Unfin Low/Level  
 Full Basement F Full Baseme  
 # Of Bedrooms 05 Five Bedroo  
 Sq.Ft.Grd Area 2859

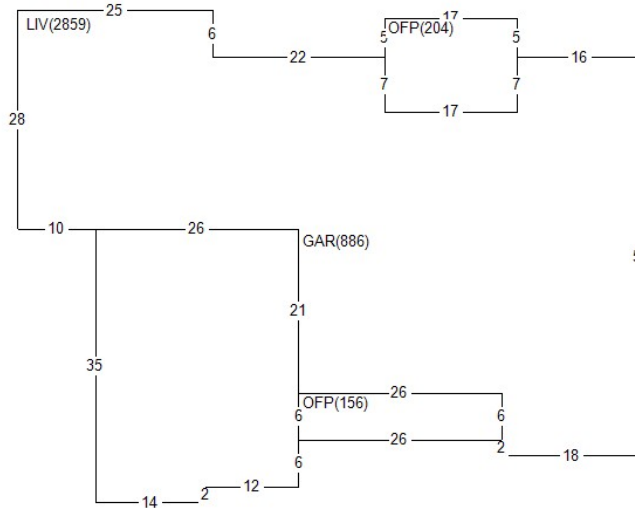

Land Value 97,570  
 Misc Value 56,790  
 Bldg Value 777,130  
 Total Value 931,490  
 Value By CAMA

RCN 711,552  
 Pct Good 0.9800  
 Obsol/Observed 0.0000  
 Building Value 697,320

DOCUMENT #	DATE	QS	SALE PRICE
425496	0822	Q	695,000
420551	1021	U	323,423
415194	0221	U	

PERMIT NO	TYPE	DATE	AMOUNT
BP-18-181	08	1018	
BP-18-018	00	0818	
BP-18-018	01	0218	

Appraiser JB J. Brown  
 Appr Date 05/21/25  
 Use Code 0030 UnImp. Res.  
 NBHD 411.10 BRELLINGER 1.0  
 L100 M100 B260

AREA	FLAT	EFF% E/AREA	ACT% A/AREA	EA/AA	HEATED
LIV	2859	1.00	2859	1.00	2859
GAR	886	1.00	886	1.00	886
OFP	360	1.00	360	1.00	360
BSML	2663	1.00	2663	1.00	2663

MISC BLDG CODE	DESC	LENGTH	WIDTH	UNITS	ADJ PRICE	EYB DT	PCT	ADJUSTMENT	VALUE
1 1 CONDR	Concrete Drivewa	.00	.00	1901.00	3.65	2018 A	2.00	1.00	6,800
2 1 OFP	Open Frame Porch	26.00	6.00	156.00	23.86	2018 A	2.00	1.00	3,650
3 1 OFP	Open Frame Porch	17.00	12.00	204.00	22.83	2018 A	2.00	1.00	4,560
4 1 DORM	Dormer	.00	.00	2.00	1850.00	2018 OD	0.00	1.00	3,700
5 2 OFP	Open Frame Porch	8.00	28.00	224.00	23.25	2024 A	0.00	1.00	5,210
6 1 POOLCNC	Concrete Res Poo	36.00	16.00	576.00	48.28	2024 A	0.00	1.00	27,810

LAND LUSE DESC	ZONING	UNITS TP	PRICE	ADJUSTMENT	CODE/FACTOR	VALUE
1 0413 COLUMBIA LAND #4	CR2	34848.00 S	2.80	TW	1.00 .00 .00	97,570

Req By: DAWN 12/15/25 12:42:00 MONROE COUNTY RESIDENTIAL  
JEFFREY A TAYLOR TRUST &  
CATHERINE J TAYLOR TRUST  
1541 ANTON DR

COLUMBIA IL 62236

Site Address: 001541 ANTON DR

BLDG # 2  
Style/Stories 1.0 One Story  
Quality/Design C C-Average  
Building Use 0450 Poolhouse  
Exterior Wall F Frame  
WALL % 100 100%  
Exterior Wall 1  
WALL 1% 000 N/A  
Crawl Sp. Adj  
Slab Adjustment S Slab  
Basement  
Combination  
Attic Area  
Heat/AC Adj AC Central Air  
Comb Ht/AC Adj  
Fireplace 31 DirectVent  
Extra Fireplace 00 N/A  
Res Fixtures 0002 02 Fixtures  
Garage  
Integral Garage  
Remodeling Adj 01 No Remodeli  
Actual Year Blt 2024  
Effect Year Blt 2024  
Cond/Desir/Util A Res CDU - A  
Township Multpl 04 TOWNSHIP #0  
Funct. Obs. % 000000  
Economic Obs. % 000000  
Observed Cond % 000000  
Obs. Cond. Code  
Combination A  
Comb A Ht/AC  
Unfin Low/Level  
Full Basement  
# Of Bedrooms 00 N/A  
Sq.Ft.Grd Area 252

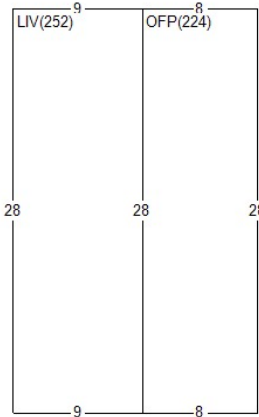

Land Value 97,570  
Misc Value 56,790  
Bldg Value 777,130  
Total Value 931,490  
Value By CAMA  
  
RCN 79,812  
Pct Good 1.0000  
Obsol/Observed 0.0000  
Building Value 79,810

DOCUMENT #	DATE	QS	SALE PRICE
414999	0221	U	
397796	0918	U	
397494	0818	U	

PERMIT NO	TYPE	DATE	AMOUNT
-----------	------	------	--------

Appraiser JB J. Brown  
Appr Date 05/21/25  
Use Code 0030 UnImp. Res.  
NBHD 411.10  
L100 M100 B260

AREA	FLAT	EFF%	E/AREA	ACT%	A/AREA	EA/AA	HEATED
LIV	252	1.00	252	1.00	252	252	252
OFF	224	1.00	224	1.00	224	224	
SLAB	252	1.00	252	1.00	252	252	

MISC BLDG CODE	DESC	LENGTH	WIDTH	UNITS	ADJ PRICE	EYB DT	PCT	ADJUSTMENT	VALUE
7 1 PTO	Concrete Patio	.00	.00	1387.00	3.65	2024 A	0.00	1.00	5,060