

Req By: DAWN
DANIEL J & SARAH M THIERET
1540 ANTON DRIVE

LOT 18 BRELLINGER 3RD ADDN SUBD

COLUMBIA IL 62236

Site Address: 001540 ANTON DR

BLDG # 1
 Style/Stories 1.0 One Story
 Quality/Design C C-Average
 Building Use 0100 Single Fami
 Exterior Wall M Masonry 1.0
 WALL % 090 090%
 Exterior Wall 1 F Frame
 WALL 1% 010 010%
 Crawl Sp. Adj
 Slab Adjustment
 Basement LC C-Living Qt
 Combination
 Attic Area
 Heat/AC Adj AC Central Air
 Comb Ht/AC Adj
 Fireplace 03 C-Fireplace
 Extra Fireplace 00 N/A
 Res Fixtures 0016 16 Fixtures
 Garage M Masonry Gar
 Integral Garage
 Remodeling Adj 01 No Remodeli
 Actual Year Blt 2020
 Effect Year Blt 2020
 Cond/Desir/Util A Res CDU - A
 Township Multpl 04 TOWNSHIP #0
 Funct. Obs. % 000000
 Economic Obs. % 000000
 Observed Cond % 000000
 Obs. Cond. Code
 Combination A
 Comb A Ht/AC
 Unfin Low/Level
 Full Basement F Full Baseme
 # Of Bedrooms 04 Four Bedroo
 Sq.Ft.Grnd Area 2940

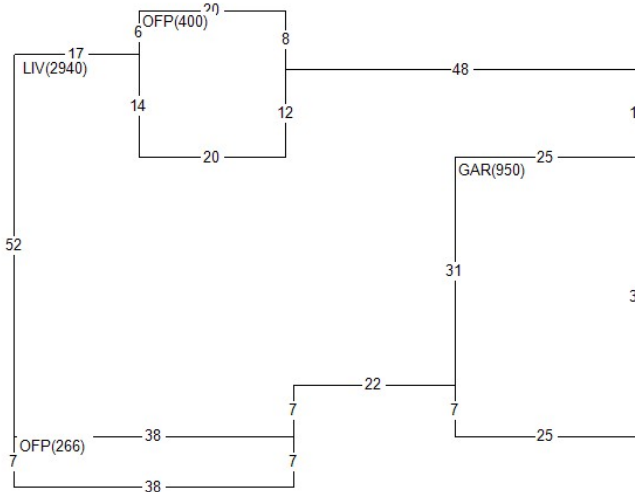

Land Value 94,920
 Misc Value 61,880
 Bldg Value 677,750
 Total Value 834,550
 Value By CAMA

RCN 684,596
 Pct Good 0.9900
 Obsol/Observed 0.0000
 Building Value 677,750

DOCUMENT # DATE QS SALE PRICE
 387337 1216 Q 81,500

PERMIT NO TYPE DATE AMOUNT
 20-6155 08 0920
 20-6154 10 0920
 20-4683 01 0320
 Appraiser RM R. Mueller
 Apr Date 08/08/22
 Use Code 0040 Imp Res
 NBHD 411.10 BRELLINGER 1.0
 L100 M100 B260

AREA	FLAT	EFF% E/AREA	ACT% A/AREA	EA/AA HEATED
LIV	2940	1.00	2940 1.00	2940 2940
OFF	666	1.00	666 1.00	666 666
GAR	950	1.00	950 1.00	950 950
CONDR	2282	1.00	2282 1.00	2282 2282
BSML	1470	1.00	1470 1.00	1470 1470
POOL	648	1.00	648 1.00	648 648
PTO	1276	1.00	1276 1.00	1276 1276

MISC BLDG CODE	DESC	LENGTH	WIDTH	UNITS	ADJ PRICE	EYB DT PCT	ADJUSTMENT	VALUE
1 1 OFFP	Open Frame Porch	7.00	38.00	266.00	23.49	2020 A 1.00	1.00	6,190
2 1 OFFP	Open Frame Porch	20.00	20.00	400.00	21.75	2020 A 1.00	1.00	8,610
3 1 CONDR	Concrete Drivewa	60.00	38.00	2280.00	3.65	2020 A 1.00	1.00	8,240
4 1 DORM	Dormer	.00	.00	3.00	1850.00	2020 OD 0.00	1.00	5,550
5 1 POOLCNC	Concrete Res Poo	18.00	36.00	648.00	44.70	2021 A 1.00	1.00	28,680
6 1 PTO	Concrete Patio	.00	.00	1276.00	3.65	2021 A 1.00	1.00	4,610
LAND LUSE DESC	ZONING	UNITS TP	PRICE	ADJUSTMENT	CODE/FACTOR	ADJUSTMENT	VALUE	
1 0413 COLUMBIA LAND #4	CR2	33541.20 S	2.83	TW 1.00	.00	.00	94,920	