

LOT 21 BRELLINGER 3RD ADDN SUBD

COLUMBIA IL 62236
Site Address: 000318 BRELLINGER ST

BLDG # 1
 Style/Stories 2.0 2 Story
 Quality/Design C C-Average
 Building Use 0100 Single Fami
 Exterior Wall M Masonry 2.0
 WALL % 060 060%
 Exterior Wall 1 F Frame
 WALL 1% 040 040%
 Crawl Sp. Adj
 Slab Adjustment
 Basement RC C-Rec Room
 Combination
 Attic Area
 Heat/AC Adj AC Central Air
 Comb Ht/AC Adj
 Fireplace 31 DirectVent
 Extra Fireplace 00 N/A
 Res Fixtures 0019 19 Fixtures
 Garage M Masonry Gar
 Integral Garage IG Integral Ga
 Remodeling Adj 01 No Remodeli
 Actual Year Blt 2016
 Effect Year Blt 2016
 Cond/Desir/Util A
 Township Multpl 04 TOWNSHIP #0
 Funct. Obs. % 000000
 Economic Obs. % 000000
 Observed Cond % 000000
 Obs. Cond. Code
 Combination A
 Comb A Ht/AC
 Unfin Low/Level
 Full Basement F Full Baseme
 # Of Bedrooms 04 Four Bedroo
 Sq.Ft.Grđ Area 2264

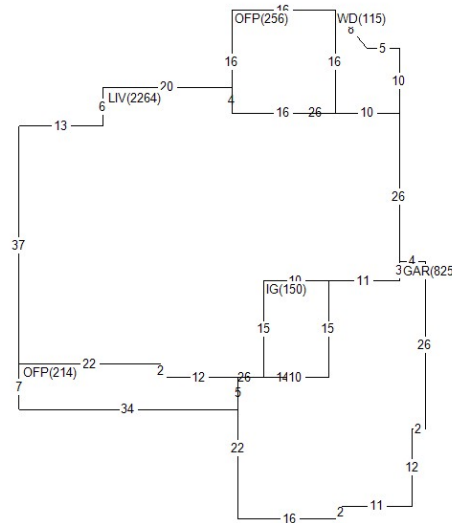

Land Value 93,440
 Misc Value 27,720
 Bldg Value 614,220
 Total Value 735,380
 Value By CAMA

RCN 633,213
 Pct Good 0.9700
 Obsol/Observed 0.0000
 Building Value 614,220

DOCUMENT # DATE QS SALE PRICE
 379032 0815 Q 90,650

PERMIT NO TYPE DATE AMOUNT
 20-5891 21 0620
 BP-15-185 00 0716
 BP-15-185 01 1115
 Appraiser DG D. Goff
 Apr Date 08/19/25
 Use Code 0040 Imp Res
 NBHD 411.20 BRELLINGER 2.0
 L100 M100 B216

AREA	FLAT	EFF% E/AREA	ACT% A/AREA	EA/AA HEATED
LIV	2264	1.00	2264 1.00	2264 2264 2264
OFFP	470	1.00	470 1.00	470 470
GAR	825	1.00	825 1.00	825 825
WD	115	1.00	115 1.00	115 115
CONDR	2142	1.00	2142 1.00	2142 2142
IG	150	1.00	150 1.00	150 150
BSMR	216	1.00	216 1.00	216 216

MISC BLDG CODE	DESC	LENGTH	WIDTH	UNITS	ADJ PRICE	EYB DT PCT	ADJUSTMENT	VALUE
1 1 OFP	Open Frame Porch	.00	.00	214.00	23.04	2016 A 3.00	1.00	4,780
2 1 OFP	Open Frame Porch	16.00	16.00	256.00	23.68	2016 A 3.00	1.00	5,880
3 1 WD	Wood Deck	.00	.00	115.00	19.35	2016 A 3.00	1.00	2,160
4 1 WD	Wood Deck	.00	.00	115.00	19.35	2016 A 3.00	1.00	2,160
5 1 CONDR	Concrete Drivewa	.00	.00	2142.00	3.65	2016 A 3.00	1.00	7,580
6 1 BRVEN	Brick Veneer	.00	.00	363.00	14.65	2016 A 3.00	1.00	5,160
LAND LUSE DESC	ZONING	UNITS TP	PRICE	ADJUSTMENT	CODE/FACTOR	ADJUSTMENT	VALUE	
1 0413 COLUMBIA LAND #4	CR2	32670.00 S	2.86	TW 1.00	.00	.00	93,440	