

Req By: DAWN
RICHARD S ERNST &
LISA M MOTTOLA ERNST
1532 ANTON DRIVE

LOT 25 BRELLINGER 3RD ADDN SUBD

COLUMBIA IL 62236

Site Address: 001532 ANTON DR

BLDG # 1
 Style/Stories 1.5 1 1/2 Story
 Quality/Design C C-Average
 Building Use 0100 Single Fami
 Exterior Wall M Masonry 1.5
 WALL % 100 100%
 Exterior Wall 1
 WALL 1% 000 N/A
 Crawl Sp. Adj C Crawl
 Slab Adjustment
 Basement RC C-Rec Room
 Combination M1 Masonry/1.0
 Attic Area
 Heat/AC Adj AC Central Air
 Comb Ht/AC Adj AC1 Cent AC Cmb
 Fireplace 03 C-Fireplace
 Extra Fireplace 00 N/A
 Res Fixtures 0015 15 Fixtures
 Garage M Masonry Gar
 Integral Garage
 Remodeling Adj 01 No Remodeli
 Actual Year Blt 2014
 Effect Year Blt 2014
 Cond/Desir/Util A
 Township Multpl 04 TOWNSHIP #0
 Funct. Obs. % 000000
 Economic Obs. % 000000
 Observed Cond % 000000
 Obs. Cond. Code
 Combination A
 Comb A Ht/AC
 Unfin Low/Level
 Full Basement F Full Baseme
 # Of Bedrooms 04 Four Bedroo
 Sq.Ft.Grnd Area 2792

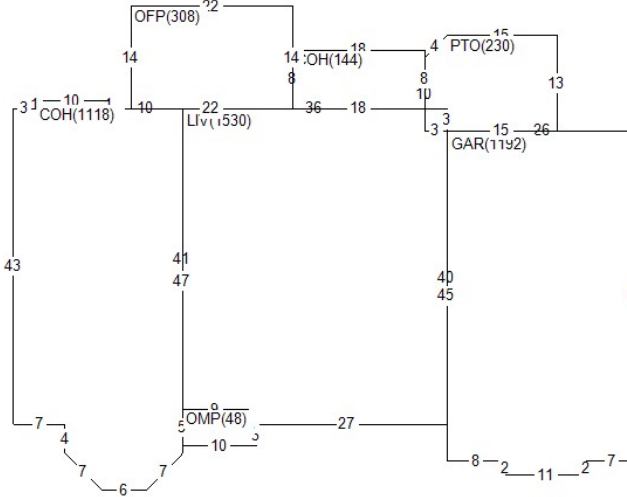

Land Value 90,000
 Misc Value 33,050
 Bldg Value 595,790
 Total Value 718,840
 Value By CAMA

RCN 620,616
 Pct Good 0.9600
 Obsol/Observed 0.0000
 Building Value 595,790

DOCUMENT #	DATE	QS	SALE PRICE
389892	0517	U	
367828	1011	04	
337934	0110	Q	75,000
PERMIT NO	TYPE	DATE	AMOUNT
BP-13-146	01	0913	

Appraiser DG D. Goff
 Appr Date 06/25/20
 Use Code 0040 Imp Res
 NBHD 411.15 BRELLINGER 1.5
 L100 M100 B216

AREA	FLAT	EFF% E/AREA	ACT% A/AREA	EA/AA	HEATED
LIV	1530	1.00	1530	1.00	1530
GAR	1192	1.00	1192	1.00	1192
COH	1262	1.00	1262	1.00	1262
PTO	538	1.00	538	1.00	538
OFF	308	1.00	308	1.00	308
OMP	48	1.00	48	1.00	48
BSMR	1080	1.00	1080	1.00	1080
CRWL	16	1.00	16	1.00	16
CONDR	4387	1.00	4387	1.00	4387

MISC BLDG CODE	DESC	LENGTH	WIDTH	UNITS	ADJ PRICE	EYB DT	PCT	ADJUSTMENT	VALUE	
1	1 OMP	Open Masonry Por	.00	.00	48.00	44.50	2014 A	4.00	1.00	2,050
2	1 PTO	Concrete Patio	.00	.00	230.00	3.65	2014 A	4.00	1.00	810
3	1 OFF	Open Frame Porch	14.00	22.00	308.00	22.74	2014 A	4.00	1.00	6,720
4	1 PTO	Concrete Patio	14.00	22.00	308.00	3.65	2014 A	4.00	1.00	1,080
5	1 CONDR	Concrete Drivewa	.00	.00	4387.00	3.65	2014 A	4.00	1.00	15,370
6	1 BRVEN	Brick Veneer	.00	.00	499.00	14.65	2014 A	4.00	1.00	7,020
LAND LUSE DESC	ZONING	UNITS	TP	PRICE	ADJUSTMENT	CODE/FACTOR	ADJUSTMENT	VALUE		
1 0413 COLUMBIA LAND #4	CR2	30927.60	S	2.91	TW	1.00	.00 .00 .00	90,000		