

LOT 172 COLUMBIA LAKES III
PHASE 3

COLUMBIA IL 62236
Site Address: 000310 MICAH'S WY

BLDG # 1
Style/Stories 1.0 One Story
Quality/Design C C-Average
Building Use 0100 Single Fami
Exterior Wall F Frame
WALL % 100 100%
Exterior Wall 1
WALL 1% 000 N/A
Crawl Sp. Adj C Crawl
Slab Adjustment
Basement RC C-Rec Room
Combination
Attic Area
Heat/AC Adj AC Central Air
Comb Ht/AC Adj
Fireplace 03 C-Fireplace
Extra Fireplace 00 N/A
Res Fixtures 0012 12 Fixtures
Garage F Frame Garag
Integral Garage
Remodeling Adj 01 No Remodeli
Actual Year Blt 2005
Effect Year Blt 2005
Cond/Desir/Util A Res CDU - A
Township Multpl 04 TOWNSHIP #0
Funct. Obs. %
Economic Obs. %
Observed Cond %
Obs. Cond. Code
Combination A
Comb A Ht/AC
Unfin Low/Level
Full Basement F Full Baseme
Of Bedrooms 03 Three Bedro
Sq.Ft.Gr'd Area 1558

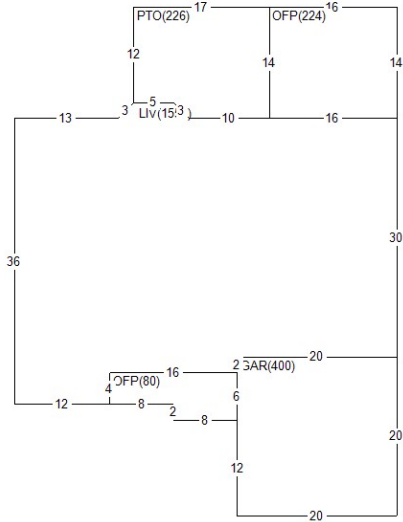

Land Value 53,860
Misc Value 12,190
Bldg Value 280,210
Total Value 346,260
Value By CAMA

RCN 314,841
Pct Good 0.8900
Obsol/Observed 0.0000
Building Value 280,210

DOCUMENT # DATE QS SALE PRICE
298072 0605 Q 197,948

PERMIT NO TYPE DATE AMOUNT
BP-09-132 09 1109
5419 00 0605
5419 01 0405
Appraiser JB J. Brown
Appr Date 08/31/23
Use Code 0040 Imp Res
NBHD 401.10 COL 1.0 2000-2009
L100 M100 B228

AREA	FLAT	EFF%	E/AREA	ACT%	A/AREA	EA/AA	HEATED
OFFP	304	1.00	304	1.00	304	304	
GAR	400	1.00	400	1.00	400	400	
LIV	1558	1.00	1558	1.00	1558	1558	1558
CRWL	14	1.00	14	1.00	14	14	
CONDR	688	1.00	688	1.00	688	688	
BSMR	720	1.00	720	1.00	720	720	
PTO	226	1.00	226	1.00	226	226	

MISC BLDG CODE	DESC	LENGTH	WIDTH	UNITS	ADJ PRICE	EYB DT	PCT	ADJUSTMENT	VALUE
1 1 OFFP	Open Frame Porch	.00	.00	80.00	29.38	2005 A	11.00	1.00	2,090
2 1 OFFP	Open Frame Porch	14.00	16.00	224.00	23.25	2022 A	1.00	1.00	5,160
3 1 CONDR	Concrete Drivewa	43.00	16.00	688.00	3.65	2005 A	11.00	1.00	2,240
4 1 BRVEN	Brick Veneer	.00	.00	144.00	14.65	2005 A	11.00	1.00	1,880
5 1 PTO	Concrete Patio	.00	.00	226.00	3.65	2022 A	1.00	1.00	820

LAND LUSE DESC	ZONING	UNITS TP	PRICE	ADJUSTMENT	CODE/FACTOR	VALUE
1 0401 COLUMBIA LAND #1	CR5	9583.20 S	5.62	TW 1.00	.00 .00 .00	53,860