

Req By: DAWN  
LAURA CARLAN  
ROBERT A JUELFIS  
3 BERRY PATCH LANE

LOT 176 COLUMBIA LAKES III  
PHASE 3

COLUMBIA IL 62236

Site Address: 002845 LAKE SIDE DR

BLDG # 1  
 Style/Stories 1.0 One Story  
 Quality/Design C C-Average  
 Building Use 0100 Single Fami  
 Exterior Wall F Frame  
 WALL % 100 100%  
 Exterior Wall 1  
 WALL 1% 000 N/A  
 Crawl Sp. Adj C Crawl  
 Slab Adjustment  
 Basement  
 Combination  
 Attic Area  
 Heat/AC Adj AC Central Air  
 Comb Ht/AC Adj  
 Fireplace 03 C-Fireplace  
 Extra Fireplace 00 N/A  
 Res Fixtures 0009 09 Fixtures  
 Garage F Frame Garag  
 Integral Garage  
 Remodeling Adj 01 No Remodeli  
 Actual Year Blt 2005  
 Effect Year Blt 2005  
 Cond/Desir/Util A Res CDU - A  
 Township Multpl 04 TOWNSHIP #0  
 Funct. Obs. % 000000  
 Economic Obs. % 000000  
 Observed Cond % 000000  
 Obs. Cond. Code  
 Combination A  
 Comb A Ht/AC  
 Unfin Low/Level  
 Full Basement F Full Baseme  
 # Of Bedrooms 03 Three Bedro  
 Sq.Ft.Grd Area 1594

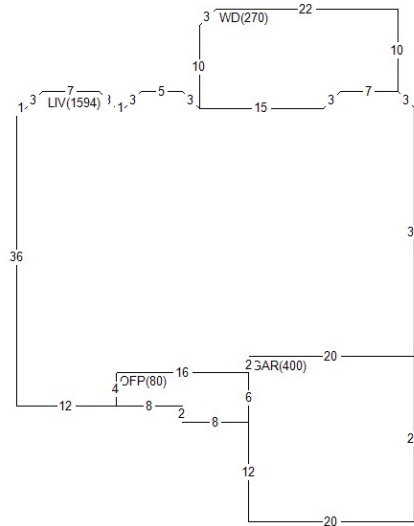

Land Value 55,750  
 Misc Value 11,550  
 Bldg Value 263,100  
 Total Value 330,400  
 Value By CAMA  
 RCN 295,620  
 Pct Good 0.8900  
 Obsol/Observed 0.0000  
 Building Value 263,100

DOCUMENT #	DATE	QS	SALE PRICE
338004	0210	U	
301162	1005	Q	213,205

PERMIT NO	TYPE	DATE	AMOUNT
BP-14-113	04	0714	
5524	01	0805	

Appraiser DG D. Goff  
 Appr Date 08/19/25  
 Use Code 0040 Imp Res  
 NBHD 401.10 COL 1.0 2000-2009  
 L100 M100 B228

AREA	FLAT	EFF%	E/AREA	ACT%	A/AREA	EA/AA	HEATED
CONDR	774	1.00	774	1.00	774	774	
CRWL	50	1.00	50	1.00	50	50	
GAR	400	1.00	400	1.00	400	400	
OFFP	80	1.00	80	1.00	80	80	
LIV	1594	1.00	1594	1.00	1594	1594	1594
WD	270	1.00	270	1.00	270	270	

MISC BLDG CODE	DESC	LENGTH	WIDTH	UNITS	ADJ PRICE	EYB DT	PCT	ADJUSTMENT	VALUE	
1	1 OFFP	Open Frame Porch	.00	.00	80.00	29.38	2005 A	11.00	1.00	2,090
2	1 CONDR	Concrete Drivewa	43.00	18.00	774.00	3.65	2005 A	11.00	1.00	2,510
3	1 BRVEN	Brick Veneer	.00	.00	144.00	14.65	2005 A	11.00	1.00	1,880
4	1 WD	Wood Deck	.00	.00	270.00	19.35	2015 A	3.00	1.00	5,070

LAND LUSE DESC	ZONING	UNITS TP	PRICE	ADJUSTMENT	CODE/FACTOR	VALUE
1 0401 COLUMBIA LAND #1	CR5	11761.20 S	4.74	TW 1.00	.00 .00	55,750