

LOT 178 COLUMBIA LAKES III  
PHASE 3

COLUMBIA IL 62236

Site Address: 002837 LAKE SIDE DR

BLDG # 1  
 Style/Stories 1.0 One Story  
 Quality/Design C C-Average  
 Building Use 0100 Single Fami  
 Exterior Wall F Frame  
 WALL % 100 100%  
 Exterior Wall 1  
 WALL 1% 000 N/A  
 Crawl Sp. Adj C Crawl  
 Slab Adjustment  
 Basement  
 Combination  
 Attic Area  
 Heat/AC Adj AC Central Air  
 Comb Ht/AC Adj  
 Fireplace 03 C-Fireplace  
 Extra Fireplace 00 N/A  
 Res Fixtures 0010 10 Fixtures  
 Garage F Frame Garag  
 Integral Garage  
 Remodeling Adj 01 No Remodeli  
 Actual Year Blt 2005  
 Effect Year Blt 2005  
 Cond/Desir/Util A Res CDU - A  
 Township Multpl 04 TOWNSHIP #0  
 Funct. Obs. % 000000  
 Economic Obs. % 000000  
 Observed Cond % 000000  
 Obs. Cond. Code  
 Combination A  
 Comb A Ht/AC  
 Unfin Low/Level  
 Full Basement F Full Baseme  
 # Of Bedrooms 03 Three Bedro  
 Sq.Ft.Grnd Area 1558

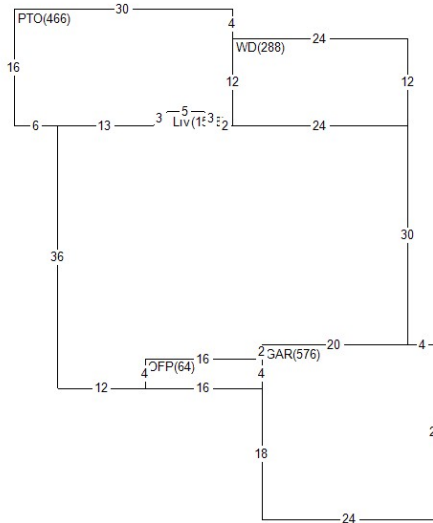

Land Value 56,850  
 Misc Value 21,950  
 Bldg Value 270,490  
 Total Value 349,290  
 Value By CAMA

RCN 303,926  
 Pct Good 0.8900  
 Obsol/Observed 0.0000  
 Building Value 270,490

DOCUMENT # DATE QS SALE PRICE  
 301453 1005 Q 220,062

PERMIT NO TYPE DATE AMOUNT  
 BP-17-092 10 0617  
 5525 01 0805

Appraiser DG D. Goff  
 Appr Date 06/09/20  
 Use Code 0040 Imp Res  
 NBHD 401.10 COL 1.0 2000-2009  
 L100 M100 B228

AREA	FLAT	EFF%	E/AREA	ACT%	A/AREA	EA/AA	HEATED
CONDR	817	1.00	817	1.00	817	817	
CRWL	14	1.00	14	1.00	14	14	
PTO	754	1.00	754	1.00	754	754	
SHED	100	1.00	100	1.00	100	100	
GAR	576	1.00	576	1.00	576	576	
OFP	64	1.00	64	1.00	64	64	
LIV	1558	1.00	1558	1.00	1558	1558	1558
WD	513	1.00	513	1.00	513	513	

MISC BLDG CODE	DESC	LENGTH	WIDTH	UNITS	ADJ PRICE	EYB DT PCT	ADJUSTMENT	VALUE
1 1 OFP	Open Frame Porch	4.00	16.00	64.00	31.88	2005 A 11.00	1.00	1,820
2 1 CONDR	Concrete Drivewa	43.00	19.00	817.00	3.65	2005 A 11.00	1.00	2,650
3 1 BRVEN	Brick Veneer	.00	.00	288.00	14.65	2005 A 11.00	1.00	3,760
4 1 WD	Wood Deck	12.00	24.00	288.00	19.35	2009 A 7.00	1.00	5,180
5 1 PTO	Concrete Patio	12.00	24.00	288.00	3.65	2009 A 7.00	1.00	980
6 1 SHED	Frame Shed	10.00	10.00	100.00	26.67	2009 A 7.00	1.00	2,480
LAND LUSE DESC	ZONING	UNITS TP	PRICE	ADJUSTMENT	CODE/FACTOR	ADJUSTMENT	VALUE	
1 0401 COLUMBIA LAND #1	CR5	13068.00 S	4.35	TW 1.00	.00	.00	56,850	

Req By: DAWN  
JAMES SHAW  
2837 LAKE SIDE DRIVE

MISC	BLDG CODE	DESC	LENGTH	WIDTH	UNITS	ADJ PRICE	EYB DT	PCT	ADJUSTMENT	VALUE
7	1 WD	Wood Deck	25.00	9.00	225.00	19.35	2018 A	2.00	1.00	4,270
8	1 PTO	Concrete Patio	.00	.00	225.00	3.65	2018 A	2.00	1.00	810

COLUMBIA IL 62236  
Site Address: 002837 LAKE SIDE DR