

LOT 177 COLUMBIA LAKES III
 PHASE 3

COLUMBIA IL 62236

Site Address: 002841 LAKE SIDE DR

BLDG # 1
 Style/Stories 1.0 One Story
 Quality/Design C C-Average
 Building Use 0100 Single Fami
 Exterior Wall F Frame
 WALL % 100 100%
 Exterior Wall 1
 WALL 1% 000 N/A
 Crawl Sp. Adj C Crawl
 Slab Adjustment
 Basement
 Combination
 Attic Area
 Heat/AC Adj AC Central Air
 Comb Ht/AC Adj
 Fireplace 03 C-Fireplace
 Extra Fireplace 00 N/A
 Res Fixtures 0010 10 Fixtures
 Garage F Frame Garag
 Integral Garage
 Remodeling Adj 01 No Remodeli
 Actual Year Blt 2006
 Effect Year Blt 2006
 Cond/Desir/Util A Res CDU - A
 Township Multpl 04 TOWNSHIP #0
 Funct. Obs. % 000000
 Economic Obs. % 000000
 Observed Cond % 000000
 Obs. Cond. Code
 Combination A
 Comb A Ht/AC
 Unfin Low/Level
 Full Basement F Full Baseme
 # Of Bedrooms 03 Three Bedro
 Sq.Ft.Grđ Area 1690

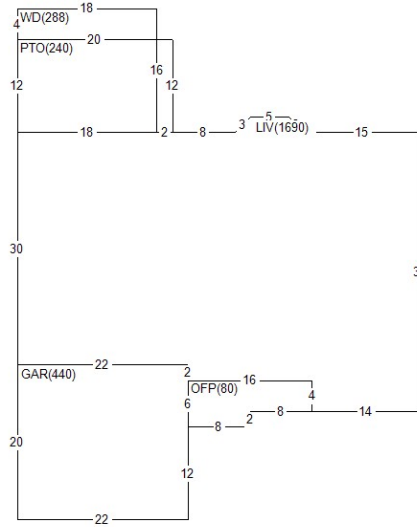

Land Value 55,750
 Misc Value 14,300
 Bldg Value 281,770
 Total Value 351,820
 Value By CAMA

RCN 313,076
 Pct Good 0.9000
 Obsol/Observed 0.0000
 Building Value 281,770

DOCUMENT #	DATE	QS	SALE PRICE
304914	0306	Q	234,349

PERMIT NO	TYPE	DATE	AMOUNT
5650	04	0306	
5596	01	1105	

Appraiser DG D. Goff
 Appr Date 06/09/20
 Use Code 0040 Imp Res
 NBHD 401.10 COL 1.0 2000-2009
 L100 M100 B228

AREA	FLAT	EFF%	E/AREA	ACT%	A/AREA	EA/AA	HEATED
CONDR	756	1.00	756	1.00	756	756	
CRWL	14	1.00	14	1.00	14	14	
OFFP	80	1.00	80	1.00	80	80	
GAR	440	1.00	440	1.00	440	440	
WD	288	1.00	288	1.00	288	288	
LIV	1690	1.00	1690	1.00	1690	1690	1690
PTO	240	1.00	240	1.00	240	240	

MISC BLDG CODE	DESC	LENGTH	WIDTH	UNITS	ADJ PRICE	EYB DT	PCT	ADJUSTMENT	VALUE
1 1 OFFP	Open Frame Porch	.00	.00	80.00	29.38	2006 A	10.00	1.00	2,120
2 1 CONDR	Concrete Drivewa	42.00	18.00	756.00	3.65	2006 A	10.00	1.00	2,480
3 1 WD	Wood Deck	16.00	18.00	288.00	19.35	2006 A	10.00	1.00	5,020
4 1 BRVEN	Brick Veneer	.00	.00	290.00	14.65	2006 A	10.00	1.00	3,820
5 1 PTO	Concrete Patio	12.00	20.00	240.00	3.65	2019 A	2.00	1.00	860

LAND LUSE DESC	ZONING	UNITS TP	PRICE	ADJUSTMENT	CODE/FACTOR	VALUE
1 0401 COLUMBIA LAND #1	CR5	11761.20 S	4.74	TW 1.00	.00 .00 .00	55,750