

LOT 209 COLUMBIA LAKES III
PHASE 3

COLUMBIA IL 62236
Site Address: 000319 MICAHS WY

BLDG # 1
 Style/Stories 2.0 2 Story
 Quality/Design C C-Average
 Building Use 0100 Single Fami
 Exterior Wall F Frame 2.0
 WALL % 100 100%
 Exterior Wall 1
 WALL 1% 000 N/A
 Crawl Sp. Adj C Crawl
 Slab Adjustment
 Basement LC C-Living Qt
 Combination F1 Frame/1.0
 Attic Area
 Heat/AC Adj AC Central Air
 Comb Ht/AC Adj AC1 Cent AC Cmb
 Fireplace 03 C-Fireplace
 Extra Fireplace 00 N/A
 Res Fixtures 0015 15 Fixtures
 Garage F Frame Garag
 Integral Garage
 Remodeling Adj 01 No Remodeli
 Actual Year Blt 2006
 Effect Year Blt 2006
 Cond/Desir/Util A Res CDU - A
 Township Multpl 04 TOWNSHIP #0
 Funct. Obs. % 000000
 Economic Obs. % 000000
 Observed Cond % 000000
 Obs. Cond. Code
 Combination A
 Comb A Ht/AC
 Unfin Low/Level
 Full Basement F Full Baseme
 # Of Bedrooms 03 Three Bedro
 Sq.Ft.Grđ Area 950

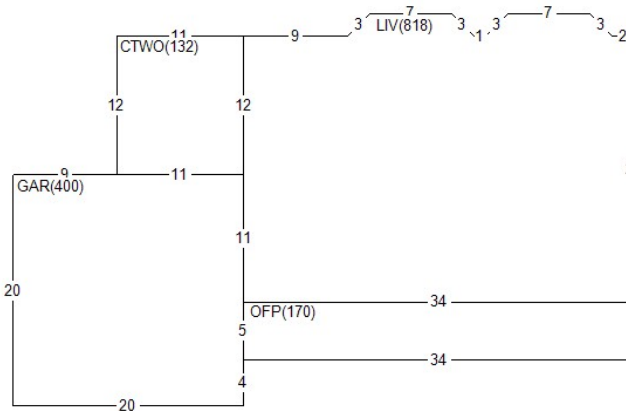

Land Value 52,800
 Misc Value 8,340
 Bldg Value 238,050
 Total Value 299,190
 Value By CAMA

RCN 264,494
 Pct Good 0.9000
 Obsol/Observed 0.0000
 Building Value 238,050

DOCUMENT #	DATE	QS	SALE PRICE
417977	0621	U	
384101	0616	Q	190,345
306506	0506	Q	204,955
PERMIT NO	TYPE	DATE	AMOUNT
20-6245	08	1020	
BP-12-032	08	0412	
BP-09-126	02	1109	
Appraiser AS A. Schwar			
Appr Date 07/12/21			
Use Code 0040 Imp Res			
NBHD	401.20	COL 2.0	2000-2009
			L100 M100 B178

AREA	FLAT	EFF% E/AREA	ACT% A/AREA	EA/AA	HEATED
CONDR	688	1.00	688	1.00	688
CRWL	36	1.00	36	1.00	36
BSML	600	1.00	600	1.00	600
SHED	100	1.00	100	1.00	100
OFFP	170	1.00	170	1.00	170
GAR	400	1.00	400	1.00	400
CTWO	132	1.00	132	1.00	132
LIV	818	1.00	818	1.00	818

MISC BLDG CODE	DESC	LENGTH	WIDTH	UNITS	ADJ PRICE	EYB DT	PCT	ADJUSTMENT	VALUE
1 1	OFFP Open Frame Porch	5.00	34.00	170.00	23.54	2006 A	10.00	1.00	3,600
2 1	CONDR Concrete Drivewa	43.00	16.00	688.00	3.65	2006 A	10.00	1.00	2,260
3 1	SHED Frame Shed	10.00	10.00	100.00	26.67	2010 A	7.00	1.00	2,480

LAND LUSE DESC	ZONING	UNITS TP	PRICE	ADJUSTMENT	CODE/FACTOR	VALUE
1 0401 COLUMBIA LAND #1	CR5	8276.40 S	6.38	TW 1.00	.00 .00	52,800