

LOT 224 COLUMBIA LAKES III  
PHASE 4

COLUMBIA IL 62236  
Site Address: 002443 LAKE SHORE DR

BLDG # 1  
 Style/Stories 1.0 One Story  
 Quality/Design C C-Average  
 Building Use 0100 Single Fami  
 Exterior Wall F Frame  
 WALL % 100 100%  
 Exterior Wall 1  
 WALL 1% 000 N/A  
 Crawl Sp. Adj C Crawl  
 Slab Adjustment  
 Basement  
 Combination  
 Attic Area  
 Heat/AC Adj AC Central Air  
 Comb Ht/AC Adj  
 Fireplace 03 C-Fireplace  
 Extra Fireplace 00 N/A  
 Res Fixtures 0009 09 Fixtures  
 Garage F Frame Garag  
 Integral Garage  
 Remodeling Adj 01 No Remodeli  
 Actual Year Blt 2005  
 Effect Year Blt 2005  
 Cond/Desir/Util A Res CDU - A  
 Township Multpl 04 TOWNSHIP #0  
 Funct. Obs. % 000000  
 Economic Obs. % 000000  
 Observed Cond % 000000  
 Obs. Cond. Code  
 Combination A  
 Comb A Ht/AC  
 Unfin Low/Level  
 Full Basement F Full Baseme  
 # Of Bedrooms 03 Three Bedro  
 Sq.Ft.Grđ Area 1708

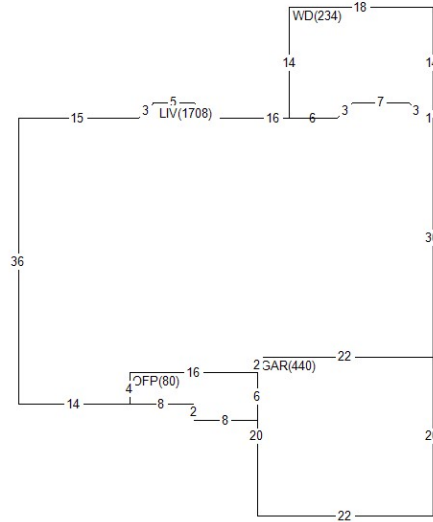

Land Value 56,470  
 Misc Value 9,470  
 Bldg Value 276,560  
 Total Value 342,500  
 Value By CAMA

RCN 310,739  
 Pct Good 0.8900  
 Obsol/Observed 0.0000  
 Building Value 276,560

DOCUMENT #	DATE	QS	SALE PRICE
414562	0121	U	239,900
383285	0616	U	
311416	1206	U	
PERMIT NO	TYPE	DATE	AMOUNT
5666	04	0406	
5566	01	0905	

Appraiser AS A. Schwar  
 Appr Date 02/02/21  
 Use Code 0040 Imp Res  
 NBHD 401.10 COL 1.0 2000-2009  
 L100 M100 B228

AREA	FLAT	EFF% E/AREA	ACT% A/AREA	EA/AA	HEATED
CONDR	704	1.00	704	1.00	704
CRWL	32	1.00	32	1.00	32
PTO	312	1.00	312	1.00	312
LIV	1708	1.00	1708	1.00	1708
WD	234	1.00	234	1.00	234
GAR	440	1.00	440	1.00	440
OFFP	80	1.00	80	1.00	80

MISC BLDG CODE	DESC	LENGTH	WIDTH	UNITS	ADJ PRICE	EYB DT PCT	ADJUSTMENT	VALUE
1	1 OFFP	Open Frame Porch	.00	.00	80.00	29.38 2005 A 11.00	1.00	2,090
2	1 CONDR	Concrete Drivewa	44.00	16.00	704.00	3.65 2005 A 11.00	1.00	2,290
3	1 WD	Wood Deck	.00	.00	234.00	19.35 2006 A 10.00	1.00	4,080
4	1 PTO	Concrete Patio	12.00	26.00	312.00	3.65 2005 A 11.00	1.00	1,010

LAND LUSE DESC	ZONING	UNITS TP	PRICE	ADJUSTMENT	CODE/FACTOR	VALUE
1 0401 COLUMBIA LAND #1	CR5	12632.40 S	4.47	TW 1.00	.00 .00	56,470