

Req By: DAWN
PATRICIA L NOONAN
SCOTT P PISANESCHI
2417 LAKE SHORE DRIVE

LOT 244 COLUMBIA LAKES III
PHASE 4

COLUMBIA IL 62236

Site Address: 002417 LAKE SHORE DR

BLDG # 1
Style/Stories 1.0 One Story
Quality/Design C C-Average
Building Use 0100 Single Fami
Exterior Wall F Frame
WALL % 100 100%
Exterior Wall 1
WALL 1% 000 N/A
Crawl Sp. Adj C Crawl
Slab Adjustment
Basement
Combination
Attic Area
Heat/AC Adj AC Central Air
Comb Ht/AC Adj
Fireplace 31 DirectVent
Extra Fireplace 00 N/A
Res Fixtures 0008 08 Fixtures
Garage F Frame Garag
Integral Garage
Remodeling Adj 01 No Remodeli
Actual Year Blt 2008
Effect Year Blt 2008
Cond/Desir/Util A Res CDU - A
Township Multpl 04 TOWNSHIP #0
Funct. Obs. %
Economic Obs. %
Observed Cond %
Obs. Cond. Code
Combination A
Comb A Ht/AC
Unfin Low/Level
Full Basement F Full Baseme
# Of Bedrooms 03 Three Bedro
Sq.Ft.Grnd Area 1554

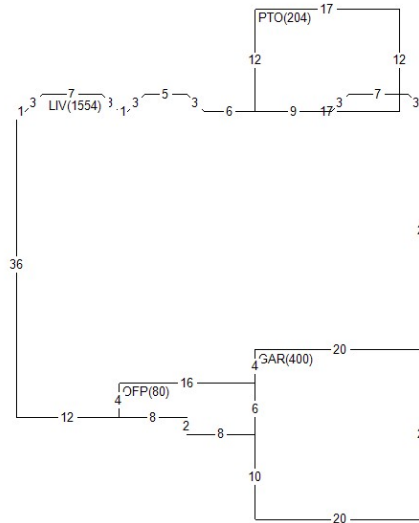

Land Value 54,680
Misc Value 7,050
Bldg Value 261,440
Total Value 323,170
Value By CAMA

RCN 284,175
Pct Good 0.9200
Obsol/Observed 0.0000
Building Value 261,440

DOCUMENT # DATE QS SALE PRICE
325928 0808 Q 204,189

PERMIT NO TYPE DATE AMOUNT
BP-08-040 01 0408

Appraiser DG D. Goff
Appr Date 06/12/20
Use Code 0040 Imp Res
NBHD 401.10 COL 1.0 2000-2009
L100 M100 B228

Table with columns: AREA, FLAT, EFF% E/AREA, ACT% A/AREA, EA/AA HEATED. Rows include CONDR, CRWL, OFP, GAR, PTO, LIV.

Table with columns: MISC BLDG CODE, DESC, LENGTH, WIDTH, UNITS, ADJ PRICE, EYB DT PCT, ADJUSTMENT, VALUE. Rows include BRVEN, PTO, CONDR, OFP.

Table with columns: LAND LUSE DESC, ZONING, UNITS TP, PRICE, ADJUSTMENT CODE/FACTOR, VALUE. Row includes 0401 COLUMBIA LAND #1 CR5.