

LOT 228 COLUMBIA LAKES III  
PHASE 4

COLUMBIA IL 62236  
Site Address: 000404 EDWARD DR

BLDG # 1  
Style/Stories 1.0 One Story  
Quality/Design C C-Average  
Building Use 0100 Single Fami  
Exterior Wall F Frame  
WALL % 100 100%  
Exterior Wall 1  
WALL 1% 000 N/A  
Crawl Sp. Adj C Crawl  
Slab Adjustment  
Basement  
Combination  
Attic Area  
Heat/AC Adj AC Central Air  
Comb Ht/AC Adj  
Fireplace 00 N/A  
Extra Fireplace 00 N/A  
Res Fixtures 0009 09 Fixtures  
Garage F Frame Garag  
Integral Garage  
Remodeling Adj 01 No Remodeli  
Actual Year Blt 2005  
Effect Year Blt 2005  
Cond/Desir/Util A  
Township Multpl 04 TOWNSHIP #0  
Funct. Obs. %  
Economic Obs. %  
Observed Cond %  
Obs. Cond. Code  
Combination A  
Comb A Ht/AC  
Unfin Low/Level  
Full Basement F Full Baseme  
# Of Bedrooms 03 Three Bedro  
Sq.Ft.Grnd Area 1654

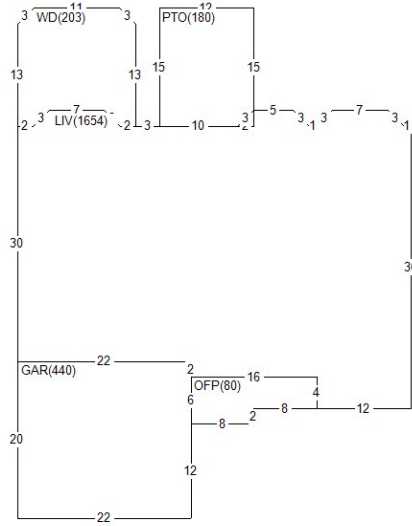

Land Value 54,680  
Misc Value 10,300  
Bldg Value 260,930  
Total Value 325,910  
Value By CAMA

RCN 293,178  
Pct Good 0.8900  
Obsol/Observed 0.0000  
Building Value 260,930

DOCUMENT # DATE QS SALE PRICE  
300160 0805 Q 197,258

PERMIT NO TYPE DATE AMOUNT  
BP-07-031 04 0307  
5445 01 0505

Appraiser DG D. Goff  
Appr Date 06/09/20  
Use Code 0040 Imp Res  
NBHD 401.10 COL 1.0 2000-2009  
L100 M100 B228

AREA	FLAT	EFF% E/AREA	ACT% A/AREA	EA/AA	HEATED
CRWL	50	1.00	50	1.00	50
CONDR	860	1.00	860	1.00	860
OFFP	80	1.00	80	1.00	80
GAR	440	1.00	440	1.00	440
WD	203	1.00	203	1.00	203
PTO	180	1.00	180	1.00	180
LIV	1654	1.00	1654	1.00	1654

MISC BLDG CODE	DESC	LENGTH	WIDTH	UNITS	ADJ PRICE	EYB DT PCT	ADJUSTMENT	VALUE
1 1 OFFP	Open Frame Porch	.00	.00	80.00	29.38	2005 A 11.00	1.00	2,090
2 1 PTO	Concrete Patio	15.00	12.00	180.00	3.65	2005 A 11.00	1.00	590
3 1 CONDR	Concrete Drivewa	43.00	20.00	860.00	3.65	2005 A 11.00	1.00	2,790
4 1 BRVEN	Brick Veneer	.00	.00	102.00	14.65	2005 A 11.00	1.00	1,330
5 1 WD	Wood Deck	.00	.00	203.00	19.35	2005 A 11.00	1.00	3,500

LAND LUSE DESC	ZONING	UNITS TP	PRICE	ADJUSTMENT	CODE/FACTOR	VALUE
1 0401 COLUMBIA LAND #1	CR5	10454.40 S	5.23	TW 1.00	.00 .00 .00	54,680