

LOT 185 COLUMBIA LAKES III  
 PHASE 5

COLUMBIA IL 62236

Site Address: 002809 LAKE SIDE DR

BLDG # 1  
 Style/Stories 1.0 One Story  
 Quality/Design C C-Average  
 Building Use 0100 Single Fami  
 Exterior Wall F Frame  
 WALL % 100 100%  
 Exterior Wall 1  
 WALL 1% 000 N/A  
 Crawl Sp. Adj C Crawl  
 Slab Adjustment  
 Basement LC C-Living Qt  
 Combination  
 Attic Area  
 Heat/AC Adj AC Central Air  
 Comb Ht/AC Adj  
 Fireplace 31 DirectVent  
 Extra Fireplace 00 N/A  
 Res Fixtures 0012 12 Fixtures  
 Garage F Frame Garag  
 Integral Garage  
 Remodeling Adj 01 No Remodeli  
 Actual Year Blt 2009  
 Effect Year Blt 2009  
 Cond/Desir/Util A  
 Township Multpl 04 TOWNSHIP #0  
 Funct. Obs. %  
 Economic Obs. %  
 Observed Cond %  
 Obs. Cond. Code  
 Combination A  
 Comb A Ht/AC  
 Unfin Low/Level  
 Full Basement F Full Baseme  
 # Of Bedrooms 04 Four Bedroo  
 Sq.Ft.Grđ Area 1726

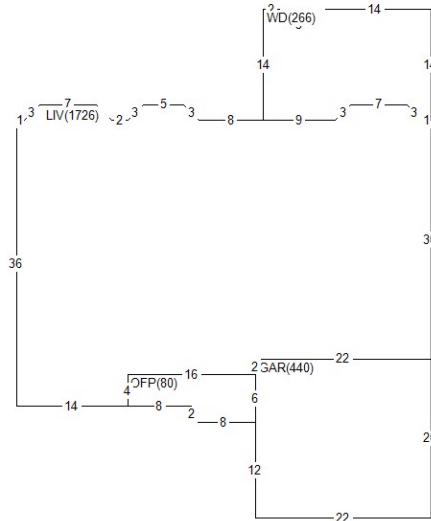

Land Value 65,860  
 Misc Value 16,040  
 Bldg Value 312,810  
 Total Value 394,710  
 Value By CAMA

RCN 336,352  
 Pct Good 0.9300  
 Obsol/Observed 0.0000  
 Building Value 312,810

DOCUMENT #	DATE	QS	SALE PRICE
382681	0416	04	
328564	0109	Q	239,300

PERMIT NO	TYPE	DATE	AMOUNT
22-7409	40	0522	
BP-13-155	04	0913	
BP-09-058	02	0609	

Appraiser DG D. Goff  
 Appr Date 08/19/25  
 Use Code 0040 Imp Res  
 NBHD 401.10 COL 1.0 2000-2009  
 L100 M100 B228

AREA	FLAT	EFF% E/AREA	ACT% A/AREA	EA/AA	HEATED
PTO	444	1.00	444	1.00	444
CONDR	756	1.00	756	1.00	756
CRWL	50	1.00	50	1.00	50
SHED	100	1.00	100	1.00	100
BSML	1000	1.00	1000	1.00	1000
GAR	440	1.00	440	1.00	440
OFFP	80	1.00	80	1.00	80
LIV	1726	1.00	1726	1.00	1726
WD	266	1.00	266	1.00	266

MISC BLDG CODE	DESC	LENGTH	WIDTH	UNITS	ADJ PRICE	EYB DT PCT	ADJUSTMENT	VALUE
1 1 BRVEN	Brick Veneer	.00	.00	176.00	14.65	2009 A 7.00	1.00	2,400
2 1 PTO	Concrete Patio	12.00	37.00	444.00	3.65	2009 A 7.00	1.00	1,510
4 1 OFFP	Open Frame Porch	.00	.00	80.00	29.38	2009 A 7.00	1.00	2,190
5 1 CONDR	Concrete Drivewa	42.00	18.00	756.00	3.65	2009 A 7.00	1.00	2,570
6 1 SHED	Frame Shed	10.00	10.00	100.00	26.67	2009 A 7.00	1.00	2,480
7 1 WD	Wood Deck	.00	.00	266.00	19.35	2013 A 5.00	1.00	4,890

LAND LUSE DESC	ZONING	UNITS TP	PRICE	ADJUSTMENT	CODE/FACTOR	VALUE
1 0401 COLUMBIA LAND #1	CR5	23522.40 S	2.80	TW	1.00 .00 .00 .00	65,860