

Req By: DAWN
 DINA M LIVINGSTON
 ROY L OTTEN
 111 SOUTH CEDAR BLUFF DRIVE

UNIT 5 OF COTTAGE HILLS
 CONDOMINIUMS PLAT 1

VALMEYER IL 62295

Site Address: 000111 S CEDAR BLUFF DR

BLDG # 1
 Style/Stories 2.0 2 Story
 Quality/Design C C-Average
 Building Use 0100 Single Fami
 Exterior Wall F Frame 2.0
 WALL % 100 100%
 Exterior Wall 1
 WALL 1% 000 N/A
 Crawl Sp. Adj
 Slab Adjustment S Slab
 Basement
 Combination
 Attic Area
 Heat/AC Adj AC Central Air
 Comb Ht/AC Adj
 Fireplace 00 N/A
 Extra Fireplace 00 N/A
 Res Fixtures 0010 10 Fixtures
 Garage F Frame Garag
 Integral Garage IG Integral Ga
 Remodeling Adj 01 No Remodeli
 Actual Year Blt 2006
 Effect Year Blt 2006
 Cond/Desir/Util A Res CDU - A
 Township Multpl 09 TOWNSHIP #0
 Funct. Obs. %
 Economic Obs. %
 Observed Cond %
 Obs. Cond. Code
 Combination A
 Comb A Ht/AC
 Unfin Low/Level
 Full Basement
 # Of Bedrooms 03 Three Bedro
 Sq.Ft.Grnd Area 1000

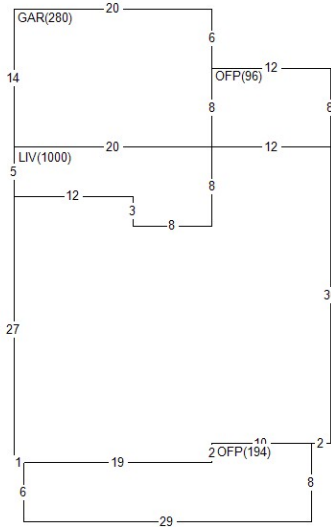

Land Value 13,380
 Misc Value 8,590
 Bldg Value 164,170
 Total Value 186,140
 Value By CAMA

RCN 182,410
 Pct Good 0.9000
 Obsol/Observed 0.0000
 Building Value 164,170

DOCUMENT #	DATE	QS	SALE PRICE
373340	1014	Q	120,000
364504	0413	U	
317365	0807	U	159,000
PERMIT NO	TYPE	DATE	AMOUNT
R4-06-01	01	0606	

Appraiser KS K. Sondag
 Aprr Date 07/21/22
 Use Code 1040 Condominium
 NBHD 62000.35 VLMYR CONDO
 L100 M100 B154

AREA	FLAT	EFF%	E/AREA	ACT%	A/AREA	EA/AA	HEATED
CONDR	432	1.00	432	1.00	432	432	
SLAB	1000	1.00	1000	1.00	1000	1000	
IG	124	1.00	124	1.00	124	124	
OFFP	290	1.00	290	1.00	290	290	
GAR	280	1.00	280	1.00	280	280	
LIV	1000	1.00	1000	1.00	1000	1000	1000

MISC BLDG CODE	DESC	LENGTH	WIDTH	UNITS	ADJ PRICE	EYB DT	PCT	ADJUSTMENT	VALUE
1 1 OFFP	Open Frame Porch	.00	.00	194.00	22.91	2006 A	10.00	1.00	4,000
2 1 OFFP	Open Frame Porch	8.00	12.00	96.00	27.48	2006 A	10.00	1.00	2,370
3 1 CONDR	Concrete Drivewa	24.00	18.00	432.00	3.65	2006 A	10.00	1.00	1,420
4 1 CONDR	Concrete Drivewa	24.00	10.00	240.00	3.65	2007 A	9.00	1.00	800

LAND LUSE DESC	ZONING	UNITS TP	PRICE	ADJUSTMENT	CODE/FACTOR	VALUE
1 6200 VALMEYER	VR4	1.00 ST	26760.00	TW 1.00 CN .50	.00	13,380