

PART LOT 3

COLUMBIA IL 62236

Site Address: 010912 LEVEE RD

BLDG # 1  
 Style/Stories SPL Split-Level  
 Quality/Design C C-Average  
 Building Use 0100 Single Fami  
 Exterior Wall F Frame SPL  
 WALL % 100 100%  
 Exterior Wall 1  
 WALL 1% 000 N/A  
 Crawl Sp. Adj C Crawl  
 Slab Adjustment  
 Basement  
 Combination M1 Masonry/1.0  
 Attic Area  
 Heat/AC Adj AC Central Air  
 Comb Ht/AC Adj AC1 Cent AC Cmb  
 Fireplace 03 C-Fireplace  
 Extra Fireplace 00 N/A  
 Res Fixtures 0010 10 Fixtures  
 Garage M Masonry Gar  
 Integral Garage  
 Remodeling Adj 01 No Remodeli  
 Actual Year Blt 1962  
 Effect Year Blt 1962  
 Cond/Desir/Util A Res CDU - A  
 Township Multpl 03 TOWNSHIP #0  
 Funct. Obs. % 000000  
 Economic Obs. % 000010  
 Observed Cond % 000000  
 Obs. Cond. Code  
 Combination A  
 Comb A Ht/AC  
 Unfin Low/Level  
 Full Basement  
 # Of Bedrooms 03 Three Bedro  
 Sq.Ft.Grd Area 1363

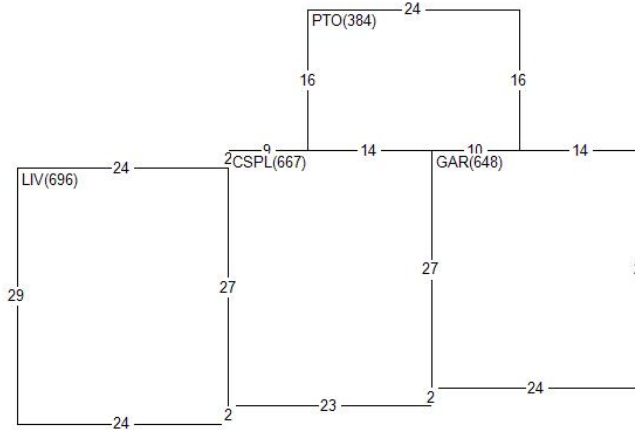

Land Value 3,000  
 Misc Value 29,710  
 Bldg Value 104,410  
 Total Value 137,120  
 Value By CAMA

RCN 232,027  
 Pct Good 0.5500  
 Obsol/Observed 0.1000  
 Building Value 104,410

DOCUMENT # DATE QS SALE PRICE  
 0368 Q

PERMIT NO TYPE DATE AMOUNT  
 14501 00 0118  
 14501 31 1117

Appraiser KK K. Kenned  
 Appr Date 01/21/22  
 Use Code 0040 Imp Res  
 NBHD 1900.10 FLD PLN 60-NEW  
 L100 M100 B154

AREA	FLAT	EFF% E/AREA	ACT% A/AREA	EA/AA HEATED
CONDR	630	1.00	630 1.00	630 630
CRWL	48	1.00	48 1.00	48 48
SHED	224	1.00	224 1.00	224 224
PTO	384	1.00	384 1.00	384 384
GAR	648	1.00	648 1.00	648 648
CSPL	667	1.00	667 1.00	667 667
LIV	696	1.00	696 1.00	696 696

MISC BLDG CODE	DESC	LENGTH	WIDTH	UNITS	ADJ PRICE	EYB DT PCT	ADJUSTMENT	VALUE
1 1 BRVEN	Brick Veneer	.00	.00	396.00	14.65	1962 A 45.00	1.00	3,190
3 1 CONDR	Concrete Drivewa	35.00	18.00	630.00	3.65	1962 A 45.00	1.00	1,270
4 1 SHED	Frame Shed	16.00	14.00	224.00	26.26	2005 A 8.00	1.00	5,410
5 1 PTO	Concrete Patio	16.00	24.00	384.00	3.65	2012 A 3.00	1.00	1,360
6 1 OFP	Open Frame Porch	12.00	12.00	144.00	24.29	2017 A 1.00	1.00	3,460
7 1 CONDR	Concrete Drivewa	15.00	15.00	225.00	3.65	2017 A 1.00	1.00	810
LAND LUSE DESC	ZONING	UNITS TP	PRICE	ADJUSTMENT	CODE/FACTOR	ADJUSTMENT	VALUE	
1 CK County Road Cat.	MAL	1.00 R	3000.00	.00	.00	.00 TW 1.00	3,000	

