

IMPR ON PART LOT 18 SUR 433 &
PART LOT 3 SEC 12

BLDG # 1
Style/Stories MH Mobil Home
Quality/Design C C-Average
Building Use 0200 Mob. Home S
Exterior Wall MH Mobile Home
WALL % 100 100%
Exterior Wall 1
WALL 1% 000 N/A
Crawl Sp. Adj MS Metal Skirt
Slab Adjustment
Basement
Combination
Attic Area
Heat/AC Adj AC Central Air
Comb Ht/AC Adj
Fireplace 00 N/A
Extra Fireplace 00 N/A
Res Fixtures 0008 08 Fixtures
Garage
Integral Garage
Remodeling Adj 01 No Remodeli
Actual Year Blt 1994
Effect Year Blt 1994
Cond/Desir/Util MH Mobile Home
Township Multpl 03 TOWNSHIP #0
Funct. Obs. % 000000
Economic Obs. % 000000
Observed Cond % 000000
Obs. Cond. Code
Combination A
Comb A Ht/AC
Unfin Low/Level
Full Basement
Of Bedrooms 02 Two Bedroom
Sq.Ft.Grd Area 1072

Site Address: 010918 LEVEE RD

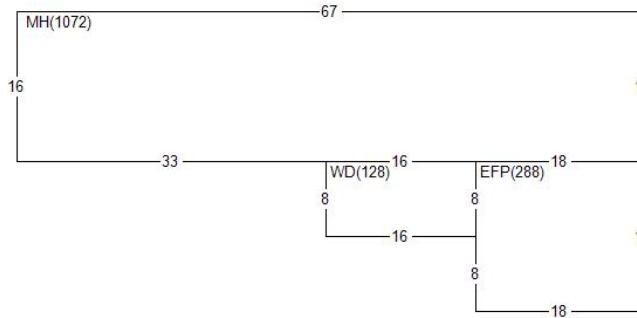

Land Value 0
Misc Value 9,170
Bldg Value 20,780
Total Value 29,950
Value By CAMA

RCN 59,372
Pct Good 0.3500
Obsol/Observed 0.0000
Building Value 20,780

DOCUMENT # DATE QS SALE PRICE

PERMIT NO TYPE DATE AMOUNT
13644 00 0216
13644 05 0714

Appraiser KS K. Sondag
Appr Date 10/27/20
Use Code 0040 Imp Res
NBHD 999.99 RUL MOBILE HOME
L100 M100 B105

AREA	FLAT	EFF% E/AREA	ACT% A/AREA	EA/AA	HEATED
EFP	288	1.00	288 1.00	288	288
WD	128	1.00	128 1.00	128	128
MH	1072	1.00	1072 1.00	1072	1072
CPT	288	1.00	288 1.00	288	288
PTO	98	1.00	98 1.00	98	98

MISC BLDG CODE	DESC	LENGTH	WIDTH	UNITS	ADJ PRICE	EYB DT	PCT	ADJUSTMENT	VALUE
1 1 EFP	Enclosed Fr. Por	16.00	18.00	288.00	37.85	1996 MH	65.00	1.00	3,820
2 1 WD	Wood Deck	8.00	16.00	128.00	19.35	1996 MH	65.00	1.00	870
3 1 CPTF	Carport Frame	24.00	12.00	288.00	9.62	1994 A	18.00	1.00	2,270
4 1 PTO	Concrete Patio	14.00	7.00	98.00	3.65	1994 A	18.00	1.00	290
5 1 CPTMTL	Carport Metal	25.00	24.00	600.00	3.27	2015 A	2.00	1.00	1,920