

VALMEYER IL 62295

Site Address: 009027 B RD

BLDG # 1
 Style/Stories 1.5 1 1/2 Story
 Quality/Design C C-Average
 Building Use 0100 Single Fami
 Exterior Wall F Frame 1.5
 WALL % 100 100%
 Exterior Wall 1
 WALL 1% 000 N/A
 Crawl Sp. Adj C Crawl
 Slab Adjustment
 Basement
 Combination F1 Frame/1.0
 Attic Area
 Heat/AC Adj AC Central Air
 Comb Ht/AC Adj AC1 Cent AC Cmb
 Fireplace 00 N/A
 Extra Fireplace 00 N/A
 Res Fixtures 0005 05 Fixtures
 Garage
 Integral Garage
 Remodeling Adj 04 1/2 - 3/4 U
 Actual Year Blt 1890
 Effect Year Blt 1890
 Cond/Desir/Util U Res CDU - U
 Township Multpl 03 TOWNSHIP #0
 Funct. Obs. % 000000
 Economic Obs. % 000000
 Observed Cond % 000000
 Obs. Cond. Code
 Combination A
 Comb A Ht/AC
 Unfin Low/Level
 Full Basement
 # Of Bedrooms 03 Three Bedro
 Sq.Ft.Grđ Area 1797

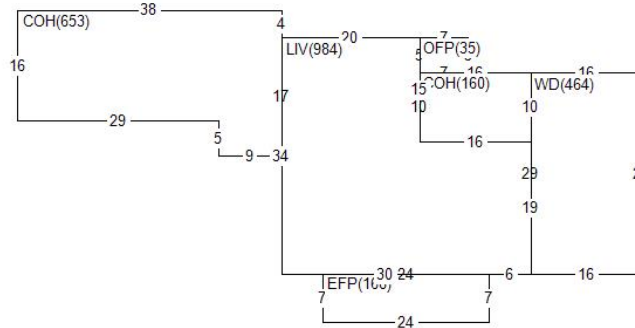

Land Value 15,000
 Misc Value 22,600
 Bldg Value 21,110
 Total Value 58,710
 Value By CAMA

RCN 211,075
 Pct Good 0.1000
 Obsol/Observed 0.0000
 Building Value 21,110

DOCUMENT #	DATE	QS	SALE PRICE
340665	0610	04	
	1178	Q	69,000

PERMIT NO	TYPE	DATE	AMOUNT
NOR		99 0919	
NOR		99 0610	

Appraiser KS K. Sondag
 Appr Date 10/28/20
 Use Code 0040 Imp Res
 NBHD 1900.30 FLD PLN PRIOR/40
 L100 M100 B144

AREA	FLAT	EFF% E/AREA	ACT% A/AREA	EA/AA HEATED
WD	464	1.00	464 1.00	464
EFP	168	1.00	168 1.00	168
COH	813	1.00	813 1.00	813
OFF	35	1.00	35 1.00	35
LIV	984	1.00	984 1.00	984 984
CRWL	1797	1.00	1797 1.00	1797 1797

MISC BLDG CODE	DESC	LENGTH	WIDTH	UNITS	ADJ PRICE	EYB DT PCT	ADJUSTMENT	VALUE
1 1 EFP	Enclosed Fr. Por	7.00	24.00	168.00	40.88	1890 F 53.00	1.00	3,230
4 1 SALV	Salvage Structur	.00	.00	2.00	300.00	00 OD 0.00	1.00	600
5 1 WD	Wood Deck	29.00	16.00	464.00	19.35	2001 P 27.00	1.00	6,550
6 1 SHED	Frame Shed	42.00	24.00	1008.00	22.04	1950 A 45.00	1.00	12,220

LAND LUSE DESC	ZONING	UNITS TP	PRICE	ADJUSTMENT	CODE/FACTOR	VALUE
1 CK County Road Cat.	MA1	5.00 R	3000.00	.00	.00 TW 1.00	15,000