

Req By: RONALD ADAM L TYBERENDT & STEFANIE JOHNSON-TYBERENDT 324 W WOODLAND RIDGE

LOT 383 NEW VALMEYER PHASE 6

VALMEYER IL 62295

Site Address: 000324 W WOODLAND RIDGE

BLDG # 1
Style/Stories 1.0 One Story
Quality/Design C C-Average
Building Use 0100 Single Fami
Exterior Wall F Frame
WALL % 100 100%
Exterior Wall 1
WALL 1% 000 N/A
Crawl Sp. Adj C Crawl
Slab Adjustment S Slab
Basement RC C-Rec Room
Combination
Attic Area
Heat/AC Adj AC Central Air
Comb Ht/AC Adj
Fireplace 03 C-Fireplace
Extra Fireplace 00 N/A
Res Fixtures 0015 15 Fixtures
Garage F Frame Garag
Integral Garage
Remodeling Adj 01 No Remodeli
Actual Year Blt 2004
Effect Year Blt 2004
Cond/Desir/Util A Res CDU - A
Township Multpl 06 TOWNSHIP #0
Funct. Obs. %
Economic Obs. %
Observed Cond %
Obs. Cond. Code
Combination A
Comb A Ht/AC
Unfin Low/Level
Full Basement F Full Baseme
# Of Bedrooms 04 Four Bedroo
Sq.Ft.Grđ Area 2246

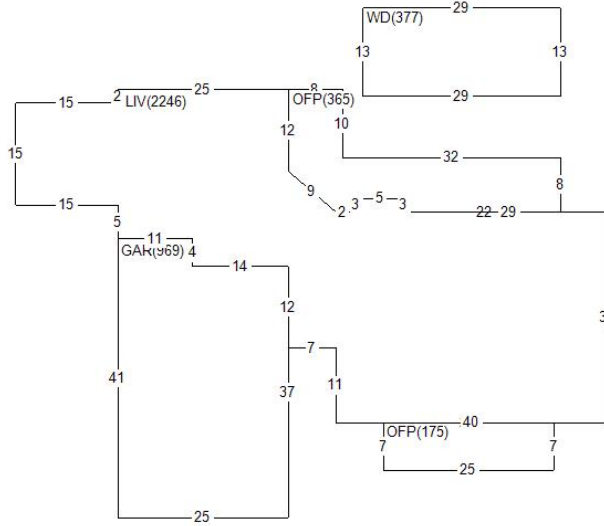

Land Value 26,760
Misc Value 27,460
Bldg Value 183,340
Total Value 237,560
Value By CAMA

RCN 199,286
Pct Good 0.9200
Obsol/Observed 0.0000
Building Value 183,340

Table with columns: DOCUMENT #, DATE, QS, SALE PRICE. Rows include 413043 (270,000), 378556 (0), 358965 (225,000), and permit information for R1-13-01 and R1-04-24.

Appraiser AS A. Schwar
Appr Date 01/07/21
Use Code 0040 Imp Res
NBHD 62000.10 VLMYR 1.0 STORY L100 M100 B107

Table with columns: AREA, FLAT, EFF% E/AREA, ACT% A/AREA, EA/AA HEATED. Rows list areas like CONDR, CRWL, BSMR, OFP, GAR, LIV, SLAB, and WD with their respective values.

Table with columns: MISC BLDG CODE, DESC, LENGTH, WIDTH, UNITS, ADJ PRICE, EYB DT PCT, ADJUSTMENT, VALUE. Rows list items like Open Frame Porch, Concrete Drivewa, Dormer, and Wood Deck.

Table with columns: LAND LUSE DESC, ZONING, UNITS TP, PRICE, ADJUSTMENT CODE/FACTOR, VALUE. Row 1: 6200 VALMEYER, VR1, 1.00 ST, 26760.00, 1.00, 0.00, 26,760.