

TAX LOT 19

WATERLOO IL 62298

Site Address: 001948 FOUNTAIN RD

BLDG # 1
 Style/Stories 1.5 1 1/2 Story
 Quality/Design C C-Average
 Building Use 0100 Single Fami
 Exterior Wall F Frame 1.5
 WALL % 100 100%
 Exterior Wall 1
 WALL 1% 000 N/A
 Crawl Sp. Adj C Crawl
 Slab Adjustment
 Basement
 Combination
 Attic Area
 Heat/AC Adj AC Central Air
 Comb Ht/AC Adj
 Fireplace 00 N/A
 Extra Fireplace 00 N/A
 Res Fixtures 0005 05 Fixtures
 Garage
 Integral Garage
 Remodeling Adj 05 Complete Re
 Actual Year Blt 1893
 Effect Year Blt 1893
 Cond/Desir/Util A Res CDU - A
 Township Multpl 06 TOWNSHIP #0
 Funct. Obs. % 000000
 Economic Obs. % 000000
 Observed Cond % 000000
 Obs. Cond. Code
 Combination A
 Comb A Ht/AC
 Unfin Low/Level
 Full Basement
 # Of Bedrooms 03 Three Bedro
 Sq.Ft.Grd Area 620

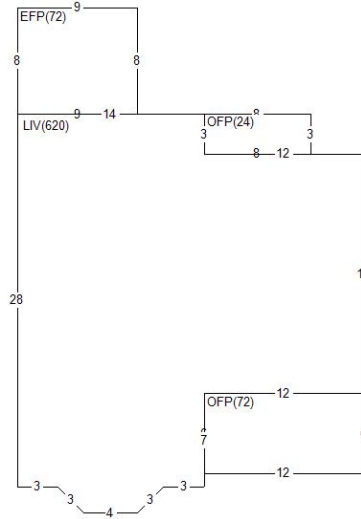

Land Value 4,050
 Misc Value 10,750
 Bldg Value 60,900
 Total Value 75,700
 Value By CAMA

RCN 110,724
 Pct Good 0.5500
 Obsol/Observed 0.0000
 Building Value 60,900

DOCUMENT #	DATE	QS	SALE PRICE
413334	1220	U	
386889	1116	Q	24,334
383938	0616	U	
PERMIT NO	TYPE	DATE	AMOUNT
11919	05	0706	

Appraiser JB J. Brown
 Appr Date 08/02/22
 Use Code 0040 Imp Res
 NBHD 1900.30 FLD PLN PRIOR/40
 L100 M100 B144

AREA	FLAT	EFF% E/AREA	ACT% A/AREA	EA/AA	HEATED
CRWL	620	1.00	620	1.00	620
OFP	96	1.00	96	1.00	96
EFP	72	1.00	72	1.00	72
LIV	620	1.00	620	1.00	620

MISC BLDG CODE	DESC	LENGTH	WIDTH	UNITS	ADJ PRICE	EYB DT	PCT	ADJUSTMENT	VALUE
1	1 OFP	6.00	12.00	72.00	30.63	1920 A	45.00	1.00	1,210
2	1 EFP	9.00	8.00	72.00	50.58	1920 A	45.00	1.00	2,000
3	1 SALV	.00	.00	1.00	300.00	00 OD	0.00	1.00	300
4	1 CPTF	20.00	30.00	600.00	9.61	1994 A	18.00	1.00	4,730
7	1 SHED	12.00	8.00	96.00	26.69	2015 A	2.00	1.00	2,510

LAND LUSE DESC	ZONING	UNITS TP	PRICE	ADJUSTMENT	CODE/FACTOR	VALUE
1 CK County Road Cat.	MR4	1.35 R	3000.00	.00	.00 TW 1.00	4,050