

PART NE NE

WATERLOO IL 62298

Site Address: 007506 D RD

BLDG # 1
 Style/Stories 2.0 2 Story
 Quality/Design C C-Average
 Building Use 0100 Single Fami
 Exterior Wall F Frame 2.0
 WALL % 100 100%
 Exterior Wall 1
 WALL 1% 000 N/A
 Crawl Sp. Adj C Crawl
 Slab Adjustment
 Basement
 Combination
 Attic Area
 Heat/AC Adj AC Central Air
 Comb Ht/AC Adj
 Fireplace C-Fireplace
 Extra Fireplace 00 N/A
 Res Fixtures 0010 10 Fixtures
 Garage F Frame Garag
 Integral Garage IG Integral Ga
 Remodeling Adj 01 No Remodeli
 Actual Year Blt 1990
 Effect Year Blt 1990
 Cond/Desir/Util A
 Township Multpl 06 TOWNSHIP #0
 Funct. Obs. % 000000
 Economic Obs. % 000000
 Observed Cond % 000000
 Obs. Cond. Code
 Combination A
 Comb A Ht/AC
 Unfin Low/Level
 Full Basement
 # Of Bedrooms 03 Three Bedro
 Sq.Ft.Grđ Area 1017

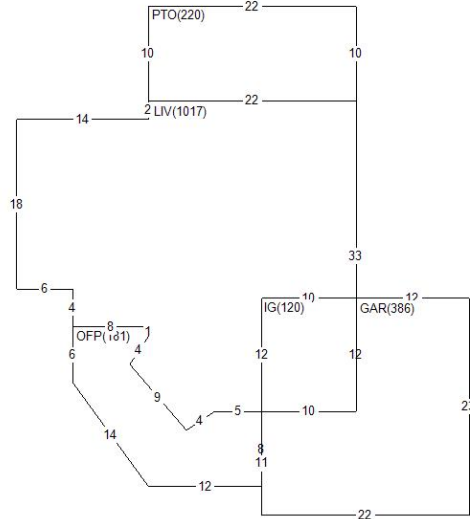

Land Value 71,380
 Misc Value 6,800
 Bldg Value 192,750
 Total Value 270,930
 Value By CAMA

RCN 247,120
 Pct Good 0.7800
 Obsol/Observed 0.0000
 Building Value 192,750

DOCUMENT #	DATE	QS	SALE PRICE
417328	0521	Q	320,000
401694	0519	U	
	0784	Q	15,000

PERMIT NO	TYPE	DATE	AMOUNT
10135	00	0901	
10135	02	0301	
6243	01	0691	

Appraiser KS K. Sondag
 Apr Date 08/02/22
 Use Code 0040 Imp Res
 NBHD 709.20 6/7&8 2.0 40/NEW
 L100 M100 B176

AREA	FLAT	EFF% E/AREA	ACT% A/AREA	EA/AA	HEATED
OFP	181	1.00	181	1.00	181
GAR	386	1.00	386	1.00	386
IG	120	1.00	120	1.00	120
PTO	220	1.00	220	1.00	220
LIV	1017	1.00	1017	1.00	1017
CRWL	366	1.00	366	1.00	366

MISC BLDG CODE	DESC	LENGTH	WIDTH	UNITS	ADJ PRICE	EYB DT PCT	ADJUSTMENT	VALUE
1 1	OFP Open Frame Porch	.00	.00	181.00	23.27	1990 A 22.00	1.00	3,290
3 1	PTO Concrete Patio	10.00	22.00	220.00	3.65	1990 F 30.00	1.00	560
5 1	PTO Concrete Patio	26.00	12.00	312.00	3.65	2001 A 12.00	1.00	1,000
6 1	PS4C08 Pole Shd 4 Sde C	40.00	24.00	960.00	13.52	2001 20 85.00	1.00	1,950

LAND LUSE DESC	ZONING	UNITS TP	PRICE	ADJUSTMENT	CODE/FACTOR	VALUE
1 CJ County Road Cat.	MA1	5.10 R	13995.67	.00	.00 TW 1.00	71,380