

PART SE NE

WATERLOO IL 62298

Site Address: 007447 D RD

BLDG # 1
 Style/Stories 1.5 1 1/2 Story
 Quality/Design C C-Average
 Building Use 0100 Single Fami
 Exterior Wall F Frame 1.5
 WALL % 100 100%
 Exterior Wall 1
 WALL 1% 000 N/A
 Crawl Sp. Adj
 Slab Adjustment
 Basement
 Combination
 Attic Area
 Heat/AC Adj AC Central Air
 Comb Ht/AC Adj
 Fireplace
 Extra Fireplace 00 N/A
 Res Fixtures 0009 09 Fixtures
 Garage F Frame Garag
 Integral Garage
 Remodeling Adj 01 No Remodeli
 Actual Year Blt 2000
 Effect Year Blt 2000
 Cond/Desir/Util A Res CDU - A
 Township Multpl 06 TOWNSHIP #0
 Funct. Obs. % 000000
 Economic Obs. % 000000
 Observed Cond % 000000
 Obs. Cond. Code
 Combination A
 Comb A Ht/AC
 Unfin Low/Level
 Full Basement F Full Baseme
 # Of Bedrooms 02 Two Bedroom
 Sq.Ft.Grd Area 888

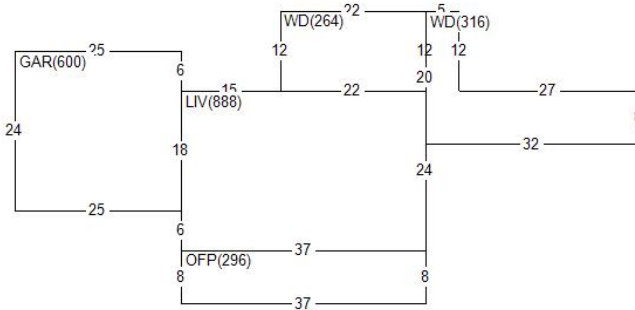

Land Value 73,410
 Misc Value 18,710
 Bldg Value 188,820
 Total Value 280,940
 Value By CAMA

RCN 214,565
 Pct Good 0.8800
 Obsol/Observed 0.0000
 Building Value 188,820

DOCUMENT #	DATE	QS	SALE PRICE
	0202	U	
	0998	U	
	0693	U	

PERMIT NO	TYPE	DATE	AMOUNT
12139	10	0507	
10473	31	0302	
9523	00	0200	

Appraiser KS K. Sondag
 Appr Date 08/02/22
 Use Code 0040 Imp Res
 NBHD 709.15 6/7&8 1.5 40/NEW
 L100 M100 B176

AREA	FLAT	EFF% E/AREA	ACT% A/AREA	EA/AA HEATED
SHED	1200	1.00	1200	1200
GAR	600	1.00	600	600
OFFP	296	1.00	296	296
WD	580	1.00	580	580
LIV	888	1.00	888	888

MISC BLDG CODE	DESC	LENGTH	WIDTH	UNITS	ADJ PRICE	EYB DT PCT	ADJUSTMENT	VALUE
1 1 WD	Wood Deck	12.00	22.00	264.00	19.35	2000 A 12.00	1.00	4,500
2 1 OFFP	Open Frame Porch	8.00	37.00	296.00	22.91	2000 A 12.00	1.00	5,970
4 1 WD	Wood Deck	.00	.00	316.00	19.35	2007 A 7.00	1.00	5,690
5 1 PS4C12	Pole Shd 4 Sde C	40.00	30.00	1200.00	14.15	2002 20 85.00	1.00	2,550

LAND LUSE DESC	ZONING	UNITS TP	PRICE	ADJUSTMENT	CODE/FACTOR	VALUE
1 CJ County Road Cat.	MA1	5.50 R	13346.40	TW 1.00	.00 .00	73,410