

PART LOT 8 EAGLE CLIFF ESTATES

WATERLOO IL 62298  
Site Address: 002304 GOLDEN EAGLE LN

BLDG # 1  
 Style/Stories 1.0 One Story  
 Quality/Design C C-Average  
 Building Use 0100 Single Fami  
 Exterior Wall M Masonry 1.0  
 WALL % 100 100%  
 Exterior Wall 1  
 WALL 1% 000 N/A  
 Crawl Sp. Adj  
 Slab Adjustment  
 Basement LC C-Living Qt  
 Combination  
 Attic Area  
 Heat/AC Adj AC Central Air  
 Comb Ht/AC Adj  
 Fireplace 24 C-2 Fr.Ones  
 Extra Fireplace 00 N/A  
 Res Fixtures 0016 16 Fixtures  
 Garage M Masonry Gar  
 Integral Garage  
 Remodeling Adj 01 No Remodeli  
 Actual Year Blt 2008  
 Effect Year Blt 2008  
 Cond/Desir/Util A Res CDU - A  
 Township Multpl 06 TOWNSHIP #0  
 Funct. Obs. %  
 Economic Obs. %  
 Observed Cond % 000000  
 Obs. Cond. Code  
 Combination A  
 Comb A Ht/AC  
 Unfin Low/Level  
 Full Basement F Full Baseme  
 # Of Bedrooms 03 Three Bedro  
 Sq.Ft.Grd Area 2580

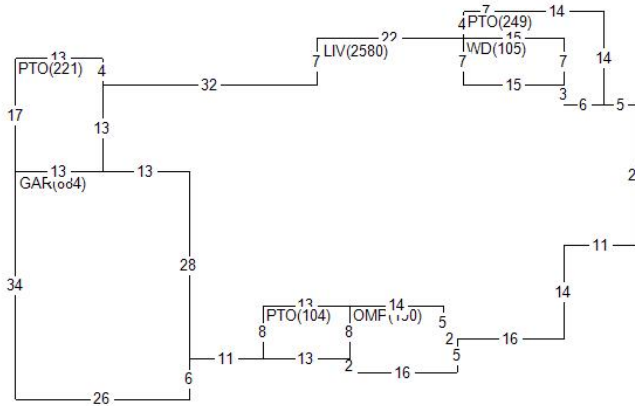

Land Value 71,630  
 Misc Value 49,260  
 Bldg Value 435,570  
 Total Value 556,460  
 Value By CAMA

RCN 463,377  
 Pct Good 0.9400  
 Obsol/Observed 0.0000  
 Building Value 435,570

DOCUMENT #	DATE	QS	SALE PRICE
391031	0717	Q	475,000
304895	0306	Q	102,500

PERMIT NO	TYPE	DATE	AMOUNT
11812	01	0406	

Appraiser KS K. Sondag  
 Appr Date 08/02/22  
 Use Code 0040 Imp Res  
 NBHD 709.08 6/7&8 1.0 2000/NE  
 L100 M100 B189

AREA	FLAT	EFF%	E/AREA	ACT%	A/AREA	EA/AA	HEATED
BSML	2580	1.00	2580	1.00	2580	2580	
WD	105	1.00	105	1.00	105	105	
OMP	150	1.00	150	1.00	150	150	
GAR	884	1.00	884	1.00	884	884	
LIV	2580	1.00	2580	1.00	2580	2580	2580
PTO	574	1.00	574	1.00	574	574	

MISC BLDG CODE	DESC	LENGTH	WIDTH	UNITS	ADJ PRICE	EYB DT PCT	ADJUSTMENT	VALUE
1 1 BRVEN	Brick Veneer	.00	.00	784.00	14.65	2008 A 6.00	1.00	10,800
3 1 WD	Wood Deck	15.00	7.00	105.00	19.35	2008 A 6.00	1.00	1,910
4 1 GARF	Garage Frame	34.00	30.00	1020.00	19.22	2008 A 6.00	1.00	18,430
5 1 BRVEN	Brick Veneer	.00	.00	128.00	14.65	2008 A 6.00	1.00	1,760
6 1 PTO	Concrete Patio	.00	.00	249.00	3.65	2011 A 4.00	1.00	870
7 1 CONDR	Concrete Drivewa	.00	.00	771.00	3.65	2015 A 2.00	1.00	2,760
LAND LUSE DESC	ZONING	UNITS	TP	PRICE	ADJUSTMENT	CODE/FACTOR	ADJUSTMENT	VALUE
1 CJ	County Road Cat. MA1	5.15	R	13908.99	.00	.00	.00 TW 1.00	71,630

Req By: KRIS\_K  
 DONALD E & SUSAN M NAUMANN  
 2304 GOLDEN EAGLE LANE

MISC BLDG CODE		DESC	Site Address:	WATERLOO	IL 62298	GOLDEN EAGLE	LN	ADJ	PRICE	EYB DT	PCT	ADJUSTMENT	VALUE
			002304	LENGTH	WIDTH	UNITS							
8	1 PTO	Concrete Patio		16.00	16.00	256.00			3.65	2015 A	2.00	1.00	920
9	1 PTO	Concrete Patio		13.00	8.00	104.00			3.65	2015 A	2.00	1.00	370
10	1 PTO	Concrete Patio		17.00	13.00	221.00			3.65	2015 A	2.00	1.00	790
11	1 PTO	Concrete Patio		.00	.00	764.00			2.99	2015 A	2.00	.82	2,240
12	1 ASP	Asphalt Driveway		.00	.00	2853.00			2.85	2019 A	1.00	1.00	8,050
13	1 PTO	Concrete Patio		15.00	8.00	120.00			2.99	2019 A	1.00	.82	360