

PART S 1/2 SE

WATERLOO IL 62298
Site Address: 006848 D RD

BLDG # 1
 Style/Stories 1.0 One Story
 Quality/Design C C-Average
 Building Use 0100 Single Fami
 Exterior Wall F Frame
 WALL % 100 100%
 Exterior Wall 1
 WALL 1% 000 N/A
 Crawl Sp. Adj
 Slab Adjustment
 Basement RC C-Rec Room
 Combination
 Attic Area
 Heat/AC Adj AC Central Air
 Comb Ht/AC Adj
 Fireplace 03 C-Fireplace
 Extra Fireplace 00 N/A
 Res Fixtures 0014 14 Fixtures
 Garage F Frame Garag
 Integral Garage
 Remodeling Adj 01 No Remodeli
 Actual Year Blt 2005
 Effect Year Blt 2005
 Cond/Desir/Util A Res CDU - A
 Township Multpl 06 TOWNSHIP #0
 Funct. Obs. %
 Economic Obs. %
 Observed Cond %
 Obs. Cond. Code
 Combination A
 Comb A Ht/AC
 Unfin Low/Level
 Full Basement F Full Baseme
 # Of Bedrooms 03 Three Bedro
 Sq.Ft.Grnd Area 2182

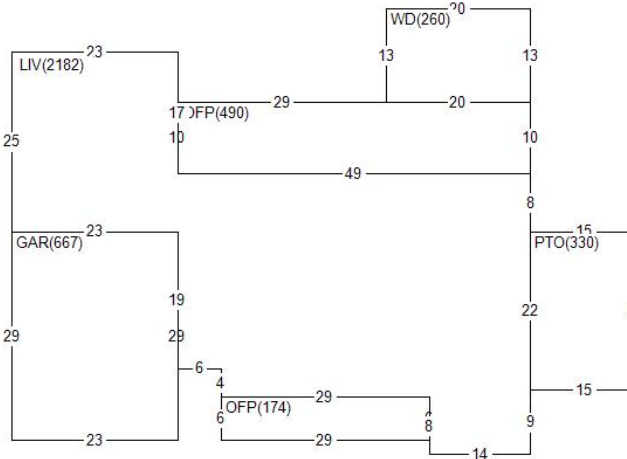

Land Value 58,200
 Misc Value 51,920
 Bldg Value 321,050
 Total Value 431,170
 Value By CAMA

RCN 348,962
 Pct Good 0.9200
 Obsol/Observed 0.0000
 Building Value 321,050

DOCUMENT #	DATE	QS	SALE PRICE
286181	0404	Q	60,000
265631	1102	U	

PERMIT NO	TYPE	DATE	AMOUNT
15671	00	0921	
15671	05	0821	
11473	00	0805	

Appraiser JB J. Brown
 Appr Date 08/05/22
 Use Code 0011 Imp. Farm
 NBHD 709.08 6/7&8 1.0 2000/NE
 L100 M100 B189

AREA	FLAT	EFF% E/AREA	ACT% A/AREA	EA/AA HEATED
CONDR	1176	1.00	1176	1176
BSMR	1320	1.00	1320	1320
OFFP	664	1.00	664	664
GAR	667	1.00	667	667
PTO	330	1.00	330	330
LIV	2182	1.00	2182	2182
WD	260	1.00	260	260

MISC BLDG CODE	DESC	LENGTH	WIDTH	UNITS	ADJ PRICE	EYB DT PCT	ADJUSTMENT	VALUE
2 1	OFFP Open Frame Porch	6.00	29.00	174.00	23.45	2005 A 8.00	1.00	3,750
3 1	OFFP Open Frame Porch	10.00	49.00	490.00	21.17	2005 A 8.00	1.00	9,540
4 1	CONDR Concrete Drivewa	.00	.00	1176.00	3.65	2005 A 8.00	1.00	3,950
5 1	PTO Concrete Patio	15.00	22.00	330.00	3.65	2007 A 7.00	1.00	1,120
6 1	DORM Dormer	.00	.00	2.00	1850.00	2005 OD 0.00	1.00	3,700
7 1	WD Wood Deck	13.00	20.00	260.00	19.35	2015 A 2.00	1.00	4,930

LAND LUSE DESC	ZONING	UNITS TP	PRICE	ADJUSTMENT	CODE/FACTOR	VALUE
1 CJ County Road Cat.	MA1	2.50 R	23280.16	TW 1.00	.00 .00 .00	58,200

Req By: KRIS_K
PATRICK & JANE MCCARTHY
6848 D RD

			WATERLOO		IL 62298						
Site Address: 006848			D		RD						
MISC	BLDG CODE	DESC	LENGTH	WIDTH	UNITS	ADJ PRICE	EYB DT	PCT	ADJUSTMENT	VALUE	
8	2	GARF	32.00	24.00	768.00	19.22	2015 A	2.00	1.00	14,470	
9	3	PS4C10	48.00	30.00	1440.00	12.80	2005 20	72.25	1.00	5,120	
10	3	PSCFL	30.00	30.00	900.00	3.65	2005 20	72.25	1.00	910	
11	3	AC	30.00	30.00	900.00	2.69	2005 20	72.25	1.00	670	
12	3	HEAT	30.00	30.00	900.00	4.61	2005 20	72.25	1.00	1,150	
13	4	CPTMTL	40.00	20.00	800.00	3.26	2021 A	0.00	1.00	2,610	