

PART LOT 2A SUR 582

WATERLOO IL 62298

Site Address: 007543 OLD BLUFF RD

BLDG # 1  
 Style/Stories 1.0 One Story  
 Quality/Design C C-Average  
 Building Use 0100 Single Fami  
 Exterior Wall F Frame  
 WALL % 100 100%  
 Exterior Wall 1  
 WALL 1% 000 N/A  
 Crawl Sp. Adj C Crawl  
 Slab Adjustment  
 Basement  
 Combination  
 Attic Area  
 Heat/AC Adj AC Central Air  
 Comb Ht/AC Adj  
 Fireplace 03 C-Fireplace  
 Extra Fireplace 00 N/A  
 Res Fixtures 0011 11 Fixtures  
 Garage F Frame Garag  
 Integral Garage  
 Remodeling Adj 04 1/2 - 3/4 U  
 Actual Year Blt 1980  
 Effect Year Blt 1980  
 Cond/Desir/Util A  
 Township Multpl 06 TOWNSHIP #0  
 Funct. Obs. % 000000  
 Economic Obs. % 000000  
 Observed Cond % 000000  
 Obs. Cond. Code  
 Combination A  
 Comb A Ht/AC  
 Unfin Low/Level  
 Full Basement F Full Baseme  
 # Of Bedrooms 04 Four Bedroo  
 Sq.Ft.Grnd Area 1976

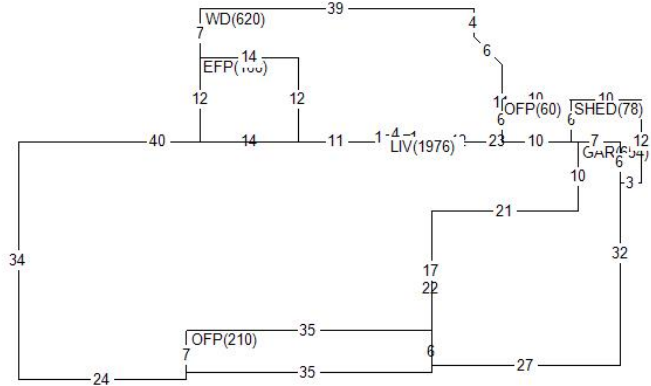

Land Value 9,000  
 Misc Value 35,200  
 Bldg Value 165,930  
 Total Value 210,130  
 Value By CAMA

RCN 244,021  
 Pct Good 0.6800  
 Obsol/Observed 0.0000  
 Building Value 165,930

DOCUMENT #	DATE	QS	SALE PRICE
0794	U		75,000

PERMIT NO	TYPE	DATE	AMOUNT
-----------	------	------	--------

Appraiser JB J. Brown  
 Appr Date 08/18/22  
 Use Code 0040 Imp Res  
 NBHD 1900.10 FLD PLN 60-NEW  
 L100 M100 B154

AREA	FLAT	EFF% E/AREA	ACT% A/AREA	EA/AA HEATED
CRWL	5	1.00	5	5
CONDR	1808	1.00	1808	1808
EFP	168	1.00	168	168
WD	620	1.00	620	620
OFFP	270	1.00	270	270
GAR	654	1.00	654	654
LIV	1976	1.00	1976	1976
SHED	78	1.00	78	78
PTO	290	1.00	290	290

MISC BLDG CODE	DESC	LENGTH	WIDTH	UNITS	ADJ PRICE	EYB DT PCT	ADJUSTMENT	VALUE
1 1 BRVEN	Brick Veneer	.00	.00	572.00	14.65	1980 A 32.00	1.00	5,700
2 1 OFFP	Open Frame Porch	6.00	35.00	210.00	22.96	1980 A 32.00	1.00	3,280
3 1 EFP	Enclosed Fr. Por	12.00	14.00	168.00	40.88	1980 A 32.00	1.00	4,670
6 1 WD	Wood Deck	.00	.00	620.00	19.35	2003 A 10.00	1.00	10,800
7 1 CONDR	Concrete Drivewa	.00	.00	1808.00	3.65	2007 A 7.00	1.00	6,140
8 1 OFFP	Open Frame Porch	6.00	10.00	60.00	32.50	2007 A 7.00	1.00	1,810
LAND LUSE DESC	ZONING	UNITS TP	PRICE	ADJUSTMENT CODE/FACTOR			VALUE	
1 CK County Road Cat.	MAL	4.00 R	3000.00	TW	1.00 CN	.75 .00	.00	9,000

MISC BLDG CODE		DESC	Site Address: 007543		UNITS	ADJ PRICE	EYB DT	PCT	ADJUSTMENT	VALUE
			LENGTH	WIDTH						
9	1	SHED	.00	.00	78.00	26.75	2007 A	7.00	1.00	1,940
10	1	PTO	.00	.00	290.00	2.99	2019 A	1.00	.82	860