

PART TAX LOT 4 & PART SUR 424 &  
PART TAX LOT 1 SEC 36

VALMEYER IL 62295  
Site Address: 000430 HAWK POINTE

BLDG # 1  
 Style/Stories 2.0 2 Story  
 Quality/Design C C-Average  
 Building Use 0100 Single Fami  
 Exterior Wall F Frame 2.0  
 WALL % 100 100%  
 Exterior Wall 1  
 WALL 1% 000 N/A  
 Crawl Sp. Adj  
 Slab Adjustment  
 Basement  
 Combination F1 Frame/1.0  
 Attic Area  
 Heat/AC Adj AC Central Air  
 Comb Ht/AC Adj AC1 Cent AC Cmb  
 Fireplace 24 C-2 Fr.Ones  
 Extra Fireplace 00 N/A  
 Res Fixtures 0013 13 Fixtures  
 Garage F Frame Garag  
 Integral Garage  
 Remodeling Adj 01 No Remodeli  
 Actual Year Blt 2004  
 Effect Year Blt 2004  
 Cond/Desir/Util A Res CDU - A  
 Township Multpl 06 TOWNSHIP #0  
 Funct. Obs. %  
 Economic Obs. %  
 Observed Cond %  
 Obs. Cond. Code  
 Combination A  
 Comb A Ht/AC  
 Unfin Low/Level  
 Full Basement F Full Baseme  
 # Of Bedrooms 04 Four Bedroo  
 Sq.Ft.Grđ Area 1433

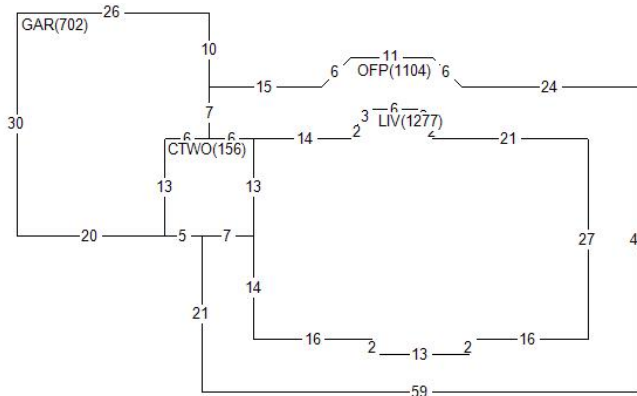

Land Value 102,900  
 Misc Value 23,790  
 Bldg Value 164,160  
 Total Value 290,850  
 Value By CAMA

RCN 180,399  
 Pct Good 0.9100  
 Obsol/Observed 0.0000  
 Building Value 164,160

DOCUMENT # DATE QS SALE PRICE  
 286311 0404 07 16,977

PERMIT NO TYPE DATE AMOUNT  
 11248 00 1204  
 11248 01 0504

Appraiser JB J. Brown  
 Appr Date 08/19/22  
 Use Code 0040 Imp Res  
 NBHD 62000.20 VLMYR 2.0 STORY  
 L100 M100 B094

AREA	FLAT	EFF% E/AREA	ACT% A/AREA	EA/AA HEATED
OFF	1104	1.00	1104	1104
GAR	702	1.00	702	702
CTWO	156	1.00	156	156
LIV	1277	1.00	1277	1277
CONDR	720	1.00	720	720
PTO	456	1.00	456	456

MISC BLDG CODE	DESC	LENGTH	WIDTH	UNITS	ADJ PRICE	EYB DT PCT	ADJUSTMENT	VALUE
1 1 OFF	Open Frame Porch	.00	.00	1104.00	19.80	2004 A 9.00	1.00	19,890
2 1 PTO	Concrete Patio	13.00	20.00	260.00	3.65	2004 A 9.00	1.00	860
3 1 PTO	Concrete Patio	.00	.00	196.00	3.65	2004 A 9.00	1.00	650
4 1 CONDR	Concrete Drivewa	24.00	30.00	720.00	3.65	2004 A 9.00	1.00	2,390

LAND LUSE DESC	ZONING	UNITS TP	PRICE	ADJUSTMENT	CODE/FACTOR	VALUE
1 CJ County Road Cat.	MA1	11.32 R	9090.33	TW 1.00	.00 .00	102,900