

LOT 373 NEW VALMEYER PHASE 6

VALMEYER IL 62295
Site Address: 000337 W WOODLAND RIDGE

BLDG # 1
 Style/Stories 1.0 One Story
 Quality/Design C C-Average
 Building Use 0100 Single Fami
 Exterior Wall F Frame
 WALL % 060 060%
 Exterior Wall 1 M Masonry
 WALL 1% 040 040%
 Crawl Sp. Adj
 Slab Adjustment
 Basement
 Combination
 Attic Area
 Heat/AC Adj AC Central Air
 Comb Ht/AC Adj
 Fireplace 00 N/A
 Extra Fireplace 00 N/A
 Res Fixtures 0009 09 Fixtures
 Garage F Frame Garag
 Integral Garage
 Remodeling Adj 01 No Remodeli
 Actual Year Blt 2003
 Effect Year Blt 2003
 Cond/Desir/Util A Res CDU - A
 Township Multpl 06 TOWNSHIP #0
 Funct. Obs. %
 Economic Obs. %
 Observed Cond %
 Obs. Cond. Code
 Combination A
 Comb A Ht/AC
 Unfin Low/Level
 Full Basement F Full Baseme
 # Of Bedrooms 03 Three Bedro
 Sq.Ft.Grd Area 1854

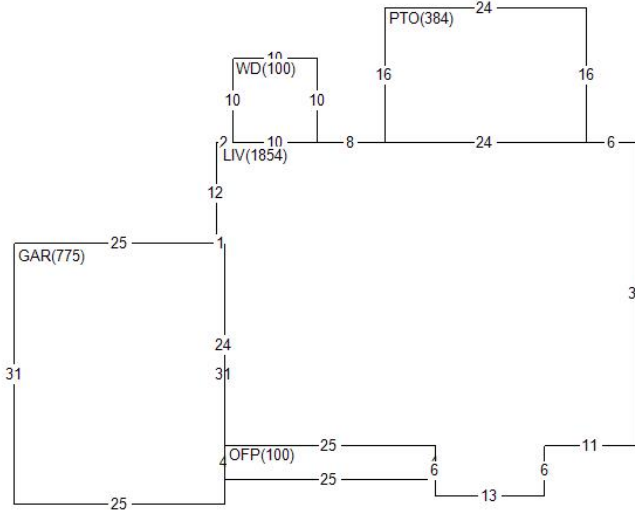

Land Value 26,760
 Misc Value 13,220
 Bldg Value 158,670
 Total Value 198,650
 Value By CAMA

RCN 176,298
 Pct Good 0.9000
 Obsol/Observed 0.0000
 Building Value 158,670

DOCUMENT #	DATE	QS	SALE PRICE
*267859	1202	Q	29,070

PERMIT NO	TYPE	DATE	AMOUNT
R1-02-44	00	0503	
R1-02-44	01	1202	

Appraiser KS K. Sondag
 Appr Date 07/05/22
 Use Code 0040 Imp Res
 NBHD 62000.10 VLMYR 1.0 STORY
 L100 M100 B118

AREA	FLAT	EFF%	E/AREA	ACT%	A/AREA	EA/AA	HEATED
CONDR	704	1.00	704	1.00	704	704	
OFP	100	1.00	100	1.00	100	100	
GAR	775	1.00	775	1.00	775	775	
WD	100	1.00	100	1.00	100	100	
LIV	1854	1.00	1854	1.00	1854	1854	1854
PTO	384	1.00	384	1.00	384	384	

MISC BLDG CODE	DESC	LENGTH	WIDTH	UNITS	ADJ PRICE	EYB DT PCT	ADJUSTMENT	VALUE
1 1 WD	Wood Deck	10.00	10.00	100.00	19.35	2003 A 10.00	1.00	1,740
2 1 OFP	Open Frame Porch	4.00	25.00	100.00	27.00	2003 A 10.00	1.00	2,430
3 1 CONDR	Concrete Drivewa	22.00	32.00	704.00	3.65	2003 A 10.00	1.00	2,310
4 1 BRVEN	Brick Veneer	.00	.00	144.00	14.65	2003 A 10.00	1.00	1,900
5 1 DORM	Dormer	.00	.00	2.00	1850.00	2003 OD 0.00	1.00	3,700
6 1 PTO	Concrete Patio	24.00	16.00	384.00	2.99	2019 A 1.00	.82	1,140
LAND LUSE DESC	ZONING	UNITS	TP	PRICE	ADJUSTMENT	CODE/FACTOR	ADJUSTMENT	VALUE
1 6200 VALMEYER	VR1	1.00	ST	26760.00	TW	1.00	.00	26,760