

LOT 377 NEW VALMEYER PHASE 6

VALMEYER IL 62295
Site Address: 000352 W WOODLAND RIDGE

BLDG # 1
 Style/Stories 2.0 2 Story
 Quality/Design C C-Average
 Building Use 0100 Single Fami
 Exterior Wall F Frame 2.0
 WALL % 100 100%
 Exterior Wall 1
 WALL 1% 000 N/A
 Crawl Sp. Adj
 Slab Adjustment
 Basement
 Combination F1 Frame/1.0
 Attic Area
 Heat/AC Adj AC Central Air
 Comb Ht/AC Adj AC1 Cent AC Cmb
 Fireplace 03 C-Fireplace
 Extra Fireplace 00 N/A
 Res Fixtures 0010 10 Fixtures
 Garage F Frame Garag
 Integral Garage
 Remodeling Adj 01 No Remodeli
 Actual Year Blt 2002
 Effect Year Blt 2002
 Cond/Desir/Util A Res CDU - A
 Township Multpl 06 TOWNSHIP #0
 Funct. Obs. %
 Economic Obs. %
 Observed Cond %
 Obs. Cond. Code
 Combination A
 Comb A Ht/AC
 Unfin Low/Level
 Full Basement F Full Baseme
 # Of Bedrooms 03 Three Bedro
 Sq.Ft.Grđ Area 1397

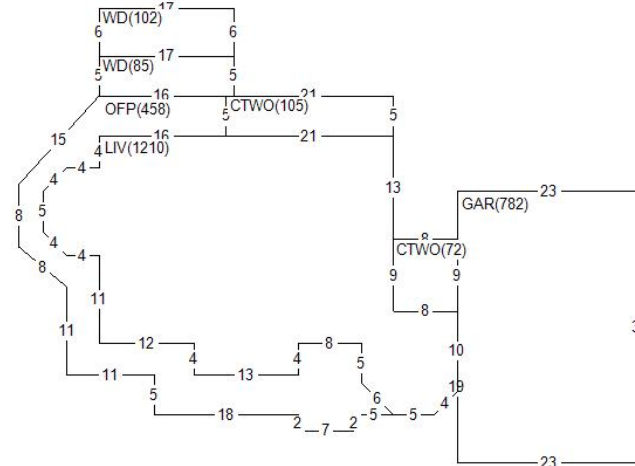

Land Value 26,760
 Misc Value 41,900
 Bldg Value 151,510
 Total Value 220,170
 Value By CAMA

RCN 170,231
 Pct Good 0.8900
 Obsol/Observed 0.0000
 Building Value 151,510

DOCUMENT #	DATE	QS	SALE PRICE
1100	U		14,488

PERMIT NO	TYPE	DATE	AMOUNT
R1-02-10	01	0502	

Appraiser KS K. Sondag
 Aprr Date 07/05/22
 Use Code 0040 Imp Res
 NBHD 62000.20 VLMYR 2.0 STORY
 L100 M100 B094

AREA	FLAT	EFF% E/AREA	ACT% A/AREA	EA/AA HEATED
CONDR	748	1.00	748	748
ASP	2171	1.00	2171	2171
POOL	512	1.00	512	512
PTO	1172	1.00	1172	1172
GAR	782	1.00	782	782
CTWO	177	1.00	177	177
WD	187	1.00	187	187
OFP	458	1.00	458	458
LIV	1210	1.00	1210	1210

MISC BLDG CODE	DESC	LENGTH	WIDTH	UNITS	ADJ PRICE	EYB DT PCT	ADJUSTMENT	VALUE
1 1 OFP	Open Frame Porch	.00	.00	458.00	21.39	2002 A 11.00	1.00	8,720
2 1 WD	Wood Deck	17.00	5.00	85.00	19.35	2002 A 11.00	1.00	1,460
4 1 CONDR	Concrete Drivewa	34.00	22.00	748.00	3.65	2002 A 11.00	1.00	2,430
5 1 ASP	Asphalt Driveway	.00	.00	2171.00	2.85	2002 A 11.00	1.00	5,510
6 1 SHED	Frame Shed	12.00	8.00	96.00	26.69	2002 A 11.00	1.00	2,280
7 1 WD	Wood Deck	6.00	17.00	102.00	19.35	2005 A 8.00	1.00	1,820
LAND LUSE DESC	ZONING	UNITS TP	PRICE	ADJUSTMENT	CODE/FACTOR	ADJUSTMENT	VALUE	
1 6200 VALMEYER	VR1	1.00 ST	26760.00	TW 1.00	.00	.00	26,760	

MISC BLDG CODE		DESC	Site Address:	VALMEYER	WOODLAND RIDGE	IL 62295									
			000352 W				LENGTH	WIDTH	UNITS	ADJ	PRICE	EYB DT	PCT	ADJUSTMENT	VALUE
8	1	POOLVNL					16.00	32.00	512.00		32.98	2007 A	7.00	1.00	15,700
9	1	PTO					.00	.00	1172.00		3.65	2007 A	7.00	1.00	3,980