

LOT 215 NEW VALMEYER PHASE 4

VALMEYER IL 62295
 Site Address: 000247 N MEYER AV

BLDG # 1
 Style/Stories 1.0 One Story
 Quality/Design C C-Average
 Building Use 0100 Single Fami
 Exterior Wall M Masonry 1.0
 WALL % 070 070%
 Exterior Wall 1 F Frame
 WALL 1% 030 030%
 Crawl Sp. Adj C Crawl
 Slab Adjustment
 Basement
 Combination
 Attic Area
 Heat/AC Adj AC Central Air
 Comb Ht/AC Adj
 Fireplace 31 DirectVent
 Extra Fireplace 00 N/A
 Res Fixtures 0014 14 Fixtures
 Garage M Masonry Gar
 Integral Garage
 Remodeling Adj 01 No Remodeli
 Actual Year Blt 2006
 Effect Year Blt 2006
 Cond/Desir/Util A Res CDU - A
 Township Multpl 06 TOWNSHIP #0
 Funct. Obs. %
 Economic Obs. %
 Observed Cond %
 Obs. Cond. Code
 Combination A
 Comb A Ht/AC
 Unfin Low/Level
 Full Basement F Full Baseme
 # Of Bedrooms 03 Three Bedro
 Sq.Ft.Grnd Area 2394

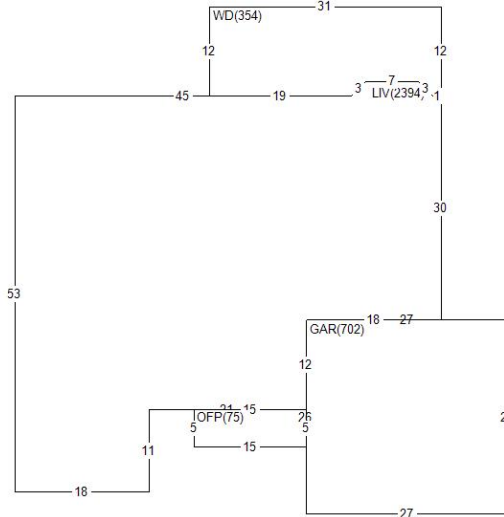

Land Value 26,760
 Misc Value 14,080
 Bldg Value 218,800
 Total Value 259,640
 Value By CAMA
 RCN 235,264
 Pct Good 0.9300
 Obsol/Observed 0.0000
 Building Value 218,800

DOCUMENT #	DATE	QS	SALE PRICE
306063	0406	U	
305137	0306	07	
305136	0306	U	
PERMIT NO	TYPE	DATE	AMOUNT
R1-06-18	01	0606	

Appraiser KS K. Sondag
 Aprr Date 07/06/22
 Use Code 0040 Imp Res
 NBHD 62000.10 VLMYR 1.0 STORY
 L100 M100 B118

AREA	FLAT	EFF%	E/AREA	ACT%	A/AREA	EA/AA	HEATED
PTO	276	1.00	276	1.00	276	276	
CONDR	1376	1.00	1376	1.00	1376	1376	
CRWL	18	1.00	18	1.00	18	18	
GAR	702	1.00	702	1.00	702	702	
LIV	2394	1.00	2394	1.00	2394	2394	2394
OFFP	75	1.00	75	1.00	75	75	
WD	354	1.00	354	1.00	354	354	

MISC BLDG CODE	DESC	LENGTH	WIDTH	UNITS	ADJ PRICE	EYB DT PCT	ADJUSTMENT	VALUE
1	1 OFFP	5.00	15.00	75.00	30.16	2006 A 7.00	1.00	2,100
2	1 WD	.00	.00	354.00	19.35	2006 A 7.00	1.00	6,370
3	1 PTO	12.00	23.00	276.00	3.65	2006 A 7.00	1.00	940
4	1 CONDR	.00	.00	1376.00	3.65	2006 A 7.00	1.00	4,670

LAND LUSE DESC	ZONING	UNITS TP	PRICE	ADJUSTMENT	CODE/FACTOR	VALUE
1 6200 VALMEYER	VR1	1.00 ST	26760.00	TW 1.00	.00 .00	26,760