

LOT 218 NEW VALMEYER PHASE 4

VALMEYER IL 62295

Site Address: 000105 OAK CT

BLDG # 1  
 Style/Stories 1.0 One Story  
 Quality/Design C C-Average  
 Building Use 0100 Single Fami  
 Exterior Wall F Frame  
 WALL % 100 100%  
 Exterior Wall 1  
 WALL 1% 000 N/A  
 Crawl Sp. Adj C Crawl  
 Slab Adjustment  
 Basement  
 Combination  
 Attic Area  
 Heat/AC Adj AC Central Air  
 Comb Ht/AC Adj  
 Fireplace 03 C-Fireplace  
 Extra Fireplace 00 N/A  
 Res Fixtures 0008 08 Fixtures  
 Garage F Frame Garag  
 Integral Garage  
 Remodeling Adj 01 No Remodeli  
 Actual Year Blt 1995  
 Effect Year Blt 1995  
 Cond/Desir/Util A Res CDU - A  
 Township Multpl 06 TOWNSHIP #0  
 Funct. Obs. % 000000  
 Economic Obs. % 000000  
 Observed Cond % 000000  
 Obs. Cond. Code  
 Combination A  
 Comb A Ht/AC  
 Unfin Low/Level  
 Full Basement  
 # Of Bedrooms 02 Two Bedroom  
 Sq.Ft.Grd Area 1352

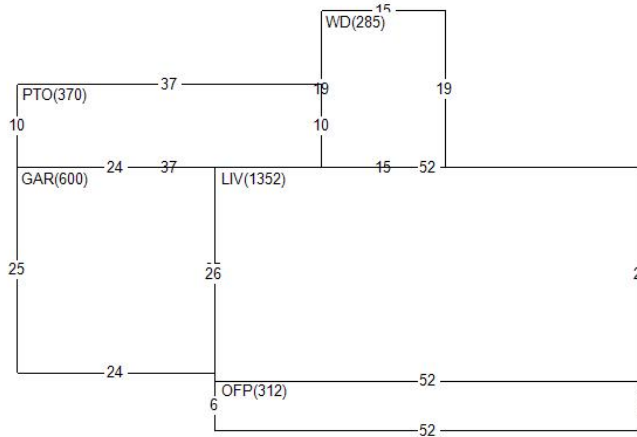

Land Value 26,760  
 Misc Value 19,470  
 Bldg Value 106,100  
 Total Value 152,330  
 Value By CAMA

RCN 127,829  
 Pct Good 0.8300  
 Obsol/Observed 0.0000  
 Building Value 106,100

DOCUMENT #	DATE	QS	SALE PRICE
423565	0422	Q	175,000
364821	0513	Q	112,000
341893	0810	U	

PERMIT NO	TYPE	DATE	AMOUNT
R1-13-02	02	0513	
R1-10-07	04	0410	
R1-94-04	01	0994	

Appraiser KS K. Sondag  
 Appr Date 07/06/22  
 Use Code 0040 Imp Res  
 NBHD 62000.10 VLMYR 1.0 STORY  
 L100 M100 B118

AREA	FLAT	EFF% E/AREA	ACT% A/AREA	EA/AA	HEATED
CONDR	1152	1.00	1152	1.00	1152
CRWL	1352	1.00	1352	1.00	1352
WD	285	1.00	285	1.00	285
PTO	370	1.00	370	1.00	370
GAR	600	1.00	600	1.00	600
LIV	1352	1.00	1352	1.00	1352
OFFP	312	1.00	312	1.00	312
SHED	144	1.00	144	1.00	144

MISC BLDG CODE	DESC	LENGTH	WIDTH	UNITS	ADJ PRICE	EYB DT	PCT	ADJUSTMENT	VALUE
1 1 OFFP	Open Frame Porch	6.00	52.00	312.00	22.70	1995 A	17.00	1.00	5,880
3 1 PTO	Concrete Patio	10.00	37.00	370.00	3.65	1995 A	17.00	1.00	1,120
4 1 CONDR	Concrete Drivewa	48.00	24.00	1152.00	3.65	1995 A	17.00	1.00	3,490
5 1 WD	Wood Deck	19.00	15.00	285.00	19.35	2010 A	5.00	1.00	5,240
6 1 SHED	Frame Shed	12.00	12.00	144.00	26.53	2014 A	2.00	1.00	3,740

LAND LUSE DESC	ZONING	UNITS TP	PRICE	ADJUSTMENT	CODE/FACTOR	VALUE
1 6200 VALMEYER	VR1	1.00 ST	26760.00	.00	.00 TW 1.00	26,760