

Req By: KRIS\_K  
JEFFREY D CHOISSER  
AMBER E CONNELL  
202 FALCON POINTE

LOT 296 NEW VALMYER PHASE 5

VALMEYER IL 62295  
Site Address: 000202 FALCON POINTE

BLDG # 1  
 Style/Stories 1.0 One Story  
 Quality/Design C C-Average  
 Building Use 0100 Single Fami  
 Exterior Wall F Frame  
 WALL % 100 100%  
 Exterior Wall 1  
 WALL 1% 000 N/A  
 Crawl Sp. Adj C Crawl  
 Slab Adjustment  
 Basement  
 Combination  
 Attic Area  
 Heat/AC Adj AC Central Air  
 Comb Ht/AC Adj  
 Fireplace 00 N/A  
 Extra Fireplace 00 N/A  
 Res Fixtures 0008 08 Fixtures  
 Garage F Frame Garag  
 Integral Garage  
 Remodeling Adj 01 No Remodeli  
 Actual Year Blt 2001  
 Effect Year Blt 2001  
 Cond/Desir/Util A  
 Township Multpl 06 TOWNSHIP #0  
 Funct. Obs. % 000000  
 Economic Obs. % 000000  
 Observed Cond % 000000  
 Obs. Cond. Code  
 Combination A  
 Comb A Ht/AC  
 Unfin Low/Level  
 Full Basement F Full Baseme  
 # Of Bedrooms 03 Three Bedro  
 Sq.Ft.Grđ Area 1330

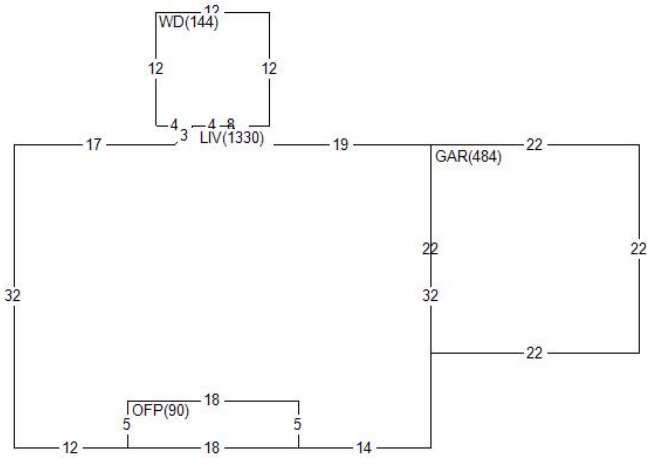

Land Value 26,760  
 Misc Value 13,690  
 Bldg Value 116,120  
 Total Value 156,570  
 Value By CAMA

RCN 131,950  
 Pct Good 0.8800  
 Obsol/Observed 0.0000  
 Building Value 116,120

| DOCUMENT # | DATE | QS   | SALE PRICE |
|------------|------|------|------------|
| 301148     | 1005 | Q    | 154,500    |
| 276952     | 0703 | Q    | 140,000    |
|            | 0301 | Q    | 22,746     |
| PERMIT NO  | TYPE | DATE | AMOUNT     |
| R1-01-19   | 04   | 0901 |            |
| R1-01-07   | 01   | 0301 |            |

Appraiser KS K. Sondag  
 Appr Date 07/07/22  
 Use Code 0040 Imp Res  
 NBHD 62000.10 VLMYR 1.0 STORY  
 L100 M100 B118

| AREA  | FLAT | EFF% E/AREA | ACT% A/AREA | EA/AA | HEATED |
|-------|------|-------------|-------------|-------|--------|
| OFFP  | 90   | 1.00        | 90          | 1.00  | 90     |
| GAR   | 484  | 1.00        | 484         | 1.00  | 484    |
| WD    | 144  | 1.00        | 144         | 1.00  | 144    |
| LIV   | 1330 | 1.00        | 1330        | 1.00  | 1330   |
| CRWL  | 12   | 1.00        | 12          | 1.00  | 12     |
| CONDR | 684  | 1.00        | 684         | 1.00  | 684    |

| MISC BLDG CODE | DESC             | LENGTH | WIDTH | UNITS  | ADJ PRICE | EYB DT | PCT   | ADJUSTMENT | VALUE |
|----------------|------------------|--------|-------|--------|-----------|--------|-------|------------|-------|
| 1 1 BRVEN      | Brick Veneer     | .00    | .00   | 528.00 | 14.65     | 2001 A | 12.00 | 1.00       | 6,810 |
| 2 1 CONDR      | Concrete Drivewa | 38.00  | 18.00 | 684.00 | 3.65      | 2001 A | 12.00 | 1.00       | 2,200 |
| 3 1 OFFP       | Open Frame Porch | 5.00   | 18.00 | 90.00  | 28.19     | 2001 A | 12.00 | 1.00       | 2,230 |
| 4 1 WD         | Wood Deck        | 12.00  | 12.00 | 144.00 | 19.35     | 2001 A | 12.00 | 1.00       | 2,450 |

| LAND LUSE DESC  | ZONING | UNITS TP | PRICE    | ADJUSTMENT | CODE/FACTOR | VALUE  |
|-----------------|--------|----------|----------|------------|-------------|--------|
| 1 6200 VALMEYER | VR1    | 1.00 ST  | 26760.00 | TW 1.00    | .00 .00     | 26,760 |