

LOT 324 NEW VALMEYER PHASE 5

VALMEYER IL 62295
Site Address: 000313 FALCON POINTE

BLDG # 1
Style/Stories 1.0 One Story
Quality/Design C C-Average
Building Use 0100 Single Fami
Exterior Wall F Frame
WALL % 100 100%
Exterior Wall 1
WALL 1% 000 N/A
Crawl Sp. Adj
Slab Adjustment
Basement RC C-Rec Room
Combination
Attic Area
Heat/AC Adj AC Central Air
Comb Ht/AC Adj
Fireplace 31 DirectVent
Extra Fireplace 00 N/A
Res Fixtures 0008 08 Fixtures
Garage F Frame Garag
Integral Garage
Remodeling Adj 01 No Remodeli
Actual Year Blt 2003
Effect Year Blt 2003
Cond/Desir/Util A
Township Multpl 06 Res CDU - A
Funct. Obs. % TOWNSHIP #0
Economic Obs. %
Observed Cond %
Obs. Cond. Code
Combination A
Comb A Ht/AC
Unfin Low/Level
Full Basement F Full Baseme
Of Bedrooms 03 Three Bedro
Sq.Ft.Grnd Area 1672

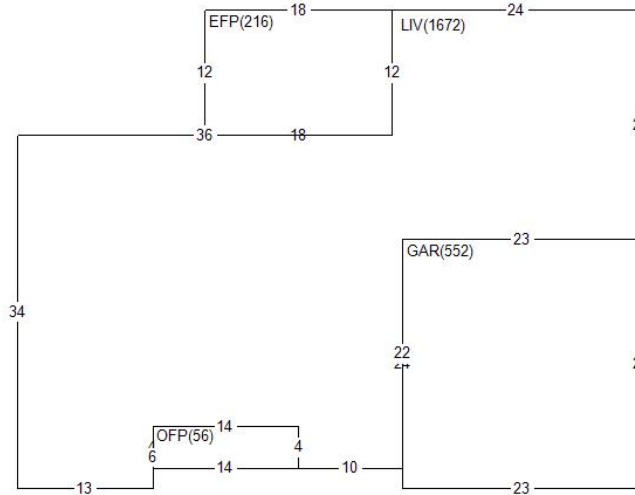

Land Value 26,760
Misc Value 13,430
Bldg Value 144,140
Total Value 184,330
Value By CAMA

RCN 160,157
Pct Good 0.9000
Obsol/Observed 0.0000
Building Value 144,140

| DOCUMENT # | DATE | QS | SALE PRICE |
|------------|------|----|------------|
| 0799 | Q | | 20,500 |
| 0895 | U | | 6,580 |
| 0595 | U | | |

| PERMIT NO | TYPE | DATE | AMOUNT |
|-----------|------|------|--------|
| R1-03-12 | 01 | 0403 | |

Appraiser KS K. Sondag
Aprr Date 07/07/22
Use Code 0040 Imp Res
NBHD 62000.10 VLMYR 1.0 STORY
L100 M100 B118

| AREA | FLAT | EFF% E/AREA | ACT% A/AREA | EA/AA HEATED |
|-------|------|-------------|-------------|--------------|
| CONDR | 480 | 1.00 | 480 | 480 |
| BSMR | 288 | 1.00 | 288 | 288 |
| OFP | 56 | 1.00 | 56 | 56 |
| GAR | 552 | 1.00 | 552 | 552 |
| EFP | 216 | 1.00 | 216 | 216 |
| LIV | 1672 | 1.00 | 1672 | 1672 |

| MISC BLDG CODE | DESC | LENGTH | WIDTH | UNITS | ADJ PRICE | EYB DT PCT | ADJUSTMENT | VALUE |
|----------------|------------------|--------|-------|--------|-----------|--------------|------------|-------|
| 1 1 OFP | Open Frame Porch | 4.00 | 14.00 | 56.00 | 34.00 | 2003 A 10.00 | 1.00 | 1,710 |
| 2 1 EFP | Enclosed Fr. Por | 12.00 | 18.00 | 216.00 | 39.15 | 2003 A 10.00 | 1.00 | 7,610 |
| 3 1 CONDR | Concrete Drivewa | 24.00 | 20.00 | 480.00 | 3.65 | 2003 A 10.00 | 1.00 | 1,580 |
| 4 1 BRVEN | Brick Veneer | .00 | .00 | 192.00 | 14.65 | 2003 A 10.00 | 1.00 | 2,530 |

| LAND LUSE DESC | ZONING | UNITS TP | PRICE | ADJUSTMENT | CODE/FACTOR | VALUE |
|-----------------|--------|----------|----------|------------|-------------|--------|
| 1 6200 VALMEYER | VR1 | 1.00 ST | 26760.00 | .00 | .00 TW 1.00 | 26,760 |