

LOT 228 NEW VALMEYER PHASE 4

VALMEYER IL 62295

Site Address: 000120 MILLER CT

BLDG # 1  
 Style/Stories 1.0 One Story  
 Quality/Design C C-Average  
 Building Use 0100 Single Fami  
 Exterior Wall F Frame  
 WALL % 100 100%  
 Exterior Wall 1  
 WALL 1% 000 N/A  
 Crawl Sp. Adj  
 Slab Adjustment  
 Basement  
 Combination  
 Attic Area  
 Heat/AC Adj AC Central Air  
 Comb Ht/AC Adj  
 Fireplace 00 N/A  
 Extra Fireplace 00 N/A  
 Res Fixtures 0008 08 Fixtures  
 Garage F Frame Garag  
 Integral Garage  
 Remodeling Adj 01 No Remodeli  
 Actual Year Blt 2004  
 Effect Year Blt 2004  
 Cond/Desir/Util A Res CDU - A  
 Township Multpl 06 TOWNSHIP #0  
 Funct. Obs. %  
 Economic Obs. %  
 Observed Cond %  
 Obs. Cond. Code  
 Combination A  
 Comb A Ht/AC  
 Unfin Low/Level  
 Full Basement F Full Baseme  
 # Of Bedrooms 03 Three Bedro  
 Sq.Ft.Grnd Area 1440

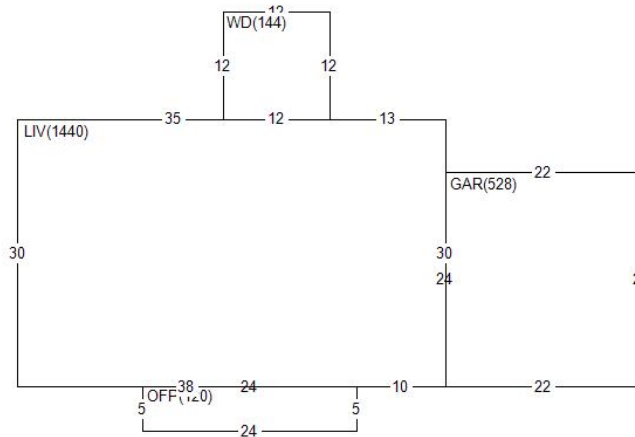

Land Value 26,760  
 Misc Value 11,130  
 Bldg Value 126,940  
 Total Value 164,830  
 Value By CAMA

RCN 139,490  
 Pct Good 0.9100  
 Obsol/Observed 0.0000  
 Building Value 126,940

DOCUMENT #	DATE	QS	SALE PRICE
309263	0906	Q	162,000
289952	0804	Q	150,377
283124	1203	Q	24,994
PERMIT NO	TYPE	DATE	AMOUNT
R1-07-21	04	0707	
R1-04-10	01	0304	

Appraiser KS K. Sondag  
 Appr Date 07/07/22  
 Use Code 0040 Imp Res  
 NBHD 62000.10 VLMYR 1.0 STORY  
 L100 M100 B118

AREA	FLAT	EFF%	E/AREA	ACT%	A/AREA	EA/AA	HEATED
CONDR	558	1.00	558	1.00	558	558	
PTO	144	1.00	144	1.00	144	144	
OFF	120	1.00	120	1.00	120	120	
GAR	528	1.00	528	1.00	528	528	
LIV	1440	1.00	1440	1.00	1440	1440	1440
WD	144	1.00	144	1.00	144	144	

MISC BLDG CODE	DESC	LENGTH	WIDTH	UNITS	ADJ PRICE	EYB DT PCT	ADJUSTMENT	VALUE
1 1 BRVEN	Brick Veneer	.00	.00	256.00	14.65	2004 A 9.00	1.00	3,410
2 1 OFP	Open Frame Porch	5.00	24.00	120.00	25.56	2004 A 9.00	1.00	2,790
3 1 CONDR	Concrete Drivewa	31.00	18.00	558.00	3.65	2004 A 9.00	1.00	1,850
4 1 WD	Wood Deck	12.00	12.00	144.00	19.35	2007 A 7.00	1.00	2,590
5 1 PTO	Concrete Patio	12.00	12.00	144.00	3.65	2007 A 7.00	1.00	490

LAND LUSE DESC	ZONING	UNITS TP	PRICE	ADJUSTMENT	CODE/FACTOR	VALUE
1 6200 VALMEYER	VR1	1.00 ST	26760.00	TW 1.00	.00 .00 .00	26,760