

LOT 236 NEW VALMEYER PHASE 4

VALMEYER IL 62295

Site Address: 000109 E RED BUD CT

BLDG # 1
 Style/Stories 1.0 One Story
 Quality/Design C C-Average
 Building Use 0100 Single Fami
 Exterior Wall F Frame
 WALL % 100 100%
 Exterior Wall 1
 WALL 1% 000 N/A
 Crawl Sp. Adj
 Slab Adjustment
 Basement RC C-Rec Room
 Combination
 Attic Area
 Heat/AC Adj AC Central Air
 Comb Ht/AC Adj
 Fireplace 00 N/A
 Extra Fireplace 00 N/A
 Res Fixtures 0013 13 Fixtures
 Garage F Frame Garag
 Integral Garage
 Remodeling Adj 01 No Remodeli
 Actual Year Blt 2000
 Effect Year Blt 2000
 Cond/Desir/Util A Res CDU - A
 Township Multpl 06 TOWNSHIP #0
 Funct. Obs. % 000000
 Economic Obs. % 000000
 Observed Cond % 000000
 Obs. Cond. Code
 Combination A
 Comb A Ht/AC
 Unfin Low/Level
 Full Basement F Full Baseme
 # Of Bedrooms 03 Three Bedro
 Sq.Ft.Grđ Area 1369

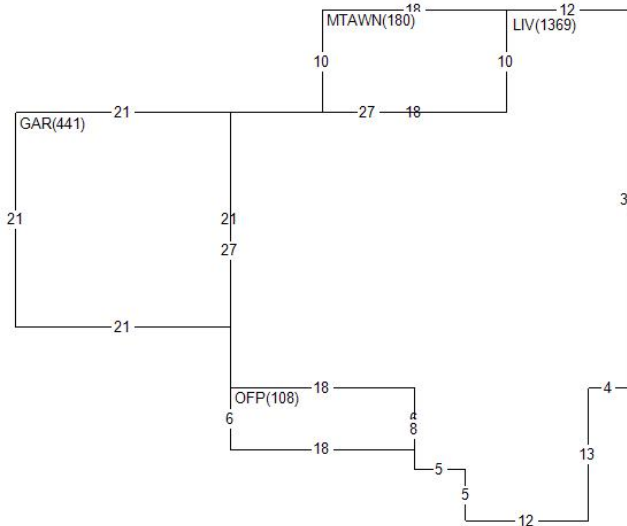

Land Value 26,760
 Misc Value 14,890
 Bldg Value 128,200
 Total Value 169,850
 Value By CAMA

RCN 145,677
 Pct Good 0.8800
 Obsol/Observed 0.0000
 Building Value 128,200

DOCUMENT #	DATE	QS	SALE PRICE
417480	0521	Q	180,000
287645	0504	U	
	0399	Q	20,828

PERMIT NO	TYPE	DATE	AMOUNT
R1-06-30	07	1006	
R1-99-04	01	0399	258

Appraiser KS K. Sondag
 Appr Date 07/08/22
 Use Code 0040 Imp Res
 NBHD 62000.10 VLMYR 1.0 STORY
 L100 M100 B118

AREA	FLAT	EFF% E/AREA	ACT% A/AREA	EA/AA	HEATED
CONDR	952	1.00	952	1.00	952
SHED	288	1.00	288	1.00	288
OFFP	108	1.00	108	1.00	108
GAR	441	1.00	441	1.00	441
MTAWN	180	1.00	180	1.00	180
LIV	1369	1.00	1369	1.00	1369
BSMR	242	1.00	242	1.00	242

MISC BLDG CODE	DESC	LENGTH	WIDTH	UNITS	ADJ PRICE	EYB DT PCT	ADJUSTMENT	VALUE
1 1 OFFP	Open Frame Porch	6.00	18.00	108.00	26.42	2000 A 12.00	1.00	2,510
3 1 CONDR	Concrete Drivewa	56.00	17.00	952.00	3.65	2000 A 12.00	1.00	3,060
4 1 MTAWN	Metal Awnings	10.00	18.00	180.00	13.98	2007 A 7.00	1.00	2,340
5 1 SHED	Frame Shed	24.00	12.00	288.00	26.05	2007 A 7.00	1.00	6,980

LAND LUSE DESC	ZONING	UNITS TP	PRICE	ADJUSTMENT	CODE/FACTOR	VALUE
1 6200 VALMEYER	VR1	1.00 ST	26760.00	TW 1.00	.00 .00	26,760