

LOT 265 NEW VALMEYER PHASE 5

VALMEYER IL 62295

Site Address: 000211 N CEDAR BLUFF DR

BLDG # 1  
 Style/Stories 1.0 One Story  
 Quality/Design C C-Average  
 Building Use 0100 Single Fami  
 Exterior Wall F Frame  
 WALL % 100 100%  
 Exterior Wall 1  
 WALL 1% 000 N/A  
 Crawl Sp. Adj  
 Slab Adjustment  
 Basement RC C-Rec Room  
 Combination  
 Attic Area  
 Heat/AC Adj AC Central Air  
 Comb Ht/AC Adj  
 Fireplace 00 N/A  
 Extra Fireplace 00 N/A  
 Res Fixtures 0011 11 Fixtures  
 Garage F Frame Garag  
 Integral Garage  
 Remodeling Adj 01 No Remodeli  
 Actual Year Blt 2002  
 Effect Year Blt 2002  
 Cond/Desir/Util A Res CDU - A  
 Township Multpl 06 TOWNSHIP #0  
 Funct. Obs. %  
 Economic Obs. %  
 Observed Cond %  
 Obs. Cond. Code  
 Combination A  
 Comb A Ht/AC  
 Unfin Low/Level  
 Full Basement F Full Baseme  
 # Of Bedrooms 03 Three Bedro  
 Sq.Ft.Grnd Area 1300

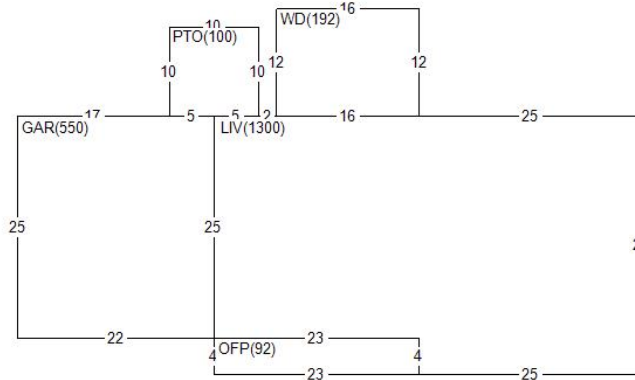

Land Value 26,760  
 Misc Value 14,070  
 Bldg Value 127,310  
 Total Value 168,140  
 Value By CAMA

RCN 143,048  
 Pct Good 0.8900  
 Obsol/Observed 0.0000  
 Building Value 127,310

DOCUMENT #	DATE	QS	SALE PRICE
408704	0620	U	
384737	0816	Q	155,000
352719	1211	Q	140,000
PERMIT NO	TYPE	DATE	AMOUNT
R1-02-27	00	1002	
R1-02-27	01	0702	

Appraiser JB J. Brown  
 Appr Date 07/08/22  
 Use Code 0040 Imp Res  
 NBHD 62000.10 VLMYR 1.0 STORY  
 L100 M100 B118

AREA	FLAT	EFF% E/AREA	ACT% A/AREA	EA/AA	HEATED
OFF	92	1.00	92	1.00	92
GAR	550	1.00	550	1.00	550
PTO	100	1.00	100	1.00	100
WD	192	1.00	192	1.00	192
LIV	1300	1.00	1300	1.00	1300
CONDR	700	1.00	700	1.00	700
BSMR	650	1.00	650	1.00	650

MISC BLDG CODE	DESC	LENGTH	WIDTH	UNITS	ADJ PRICE	EYB DT PCT	ADJUSTMENT	VALUE
1 1 CONDR	Concrete Drivewa	35.00	20.00	700.00	3.65	2002 A 11.00	1.00	2,270
2 1 OFP	Open Frame Porch	4.00	23.00	92.00	27.95	2002 A 11.00	1.00	2,290
3 1 PTO	Concrete Patio	10.00	10.00	100.00	3.65	2002 A 11.00	1.00	330
4 1 WD	Wood Deck	12.00	16.00	192.00	19.35	2002 A 11.00	1.00	3,310
5 1 BRVEN	Brick Veneer	.00	.00	248.00	14.65	2002 A 11.00	1.00	3,230
6 1 SHED	Frame Shed	10.00	10.00	100.00	26.67	2019 A 1.00	1.00	2,640
LAND LUSE DESC	ZONING	UNITS TP	PRICE	ADJUSTMENT	CODE/FACTOR	ADJUSTMENT	VALUE	
1 6200 VALMEYER	VR1	1.00 ST	26760.00	TW 1.00	.00	.00	.00	26,760