

Req By: KRIS_K
COLTON N MASSIE &
AMY AKIN
508 BLUFF MEADOWS DR

LOT 10 BLUFF MEADOWS

VALMEYER IL 62295

Site Address: 000508 BLUFF MEADOWS DR

BLDG # 1
 Style/Stories 1.0 One Story
 Quality/Design C C-Average
 Building Use 0100 Single Fami
 Exterior Wall F Frame
 WALL % 100 100%
 Exterior Wall 1
 WALL 1% 000 N/A
 Crawl Sp. Adj C Crawl
 Slab Adjustment
 Basement
 Combination
 Attic Area
 Heat/AC Adj AC Central Air
 Comb Ht/AC Adj
 Fireplace 03 C-Fireplace
 Extra Fireplace 00 N/A
 Res Fixtures 0009 09 Fixtures
 Garage F Frame Garag
 Integral Garage
 Remodeling Adj 01 No Remodeli
 Actual Year Blt 2007
 Effect Year Blt 2007
 Cond/Desir/Util A Res CDU - A
 Township Multpl 06 TOWNSHIP #0
 Funct. Obs. %
 Economic Obs. %
 Observed Cond %
 Obs. Cond. Code
 Combination A
 Comb A Ht/AC
 Unfin Low/Level
 Full Basement F Full Baseme
 # Of Bedrooms 03 Three Bedro
 Sq.Ft.Grđ Area 1422

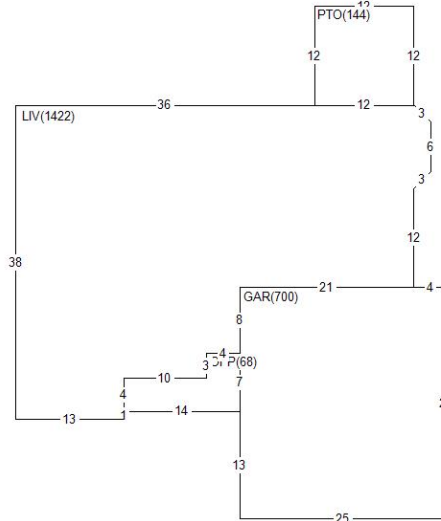

Land Value 26,760
 Misc Value 10,860
 Bldg Value 139,460
 Total Value 177,080
 Value By CAMA

RCN 149,958
 Pct Good 0.9300
 Obsol/Observed 0.0000
 Building Value 139,460

DOCUMENT #	DATE	QS	SALE PRICE
388674	0317	Q	160,000
317909	0807	Q	187,000
313686	0307	U	33,725

PERMIT NO	TYPE	DATE	AMOUNT
R1-08-04		0308	
R1-07-10	01	0507	

Appraiser KS K. Sondag
 Appr Date 07/20/22
 Use Code 0040 Imp Res
 NBHD 62000.10 VLMYR 1.0 STORY
 L100 M100 B118

AREA	FLAT	EFF%	E/AREA	ACT%	A/AREA	EA/AA	HEATED
CRWL	16	1.00	16	1.00	16	16	
CONDR	1080	1.00	1080	1.00	1080	1080	
GAR	700	1.00	700	1.00	700	700	
OFFP	68	1.00	68	1.00	68	68	
LIV	1422	1.00	1422	1.00	1422	1422	1422
PTO	144	1.00	144	1.00	144	144	

MISC BLDG CODE	DESC	LENGTH	WIDTH	UNITS	ADJ PRICE	EYB DT	PCT	ADJUSTMENT	VALUE
1 1 BRVEN	Brick Veneer	.00	.00	344.00	14.65	2007 A	7.00	1.00	4,690
2 1 PTO	Concrete Patio	12.00	12.00	144.00	3.65	2007 A	7.00	1.00	490
3 1 OFFP	Open Frame Porch	.00	.00	68.00	31.25	2007 A	7.00	1.00	1,980
4 1 CONDR	Concrete Drivewa	36.00	20.00	720.00	3.65	2007 A	7.00	1.00	2,440
5 1 CONDR	Concrete Drivewa	36.00	10.00	360.00	3.65	2011 A	4.00	1.00	1,260

LAND LUSE DESC	ZONING	UNITS TP	PRICE	ADJUSTMENT	CODE/FACTOR	VALUE
1 6200 VALMEYER	VR1	1.00 ST	26760.00	TW 1.00	.00 .00 .00	26,760