

Req By: KRIS_K
ERIN R ROEVER &
JONATHAN STOUT JR
507 CLIFF VIEW PLACE

LOT 40 BLUFF MEADOWS

VALMEYER IL 62295

Site Address: 000507 CLIFF VIEW PL

BLDG # 1
 Style/Stories 1.0 One Story
 Quality/Design C C-Average
 Building Use 0100 Single Fami
 Exterior Wall F Frame
 WALL % 100 100%
 Exterior Wall 1
 WALL 1% 000 N/A
 Crawl Sp. Adj
 Slab Adjustment
 Basement
 Combination
 Attic Area
 Heat/AC Adj AC Central Air
 Comb Ht/AC Adj
 Fireplace 00 N/A
 Extra Fireplace 00 N/A
 Res Fixtures 0008 08 Fixtures
 Garage F Frame Garag
 Integral Garage
 Remodeling Adj 01 No Remodeli
 Actual Year Blt 2014
 Effect Year Blt 2014
 Cond/Desir/Util A Res CDU - A
 Township Multpl 06 TOWNSHIP #0
 Funct. Obs. % 000000
 Economic Obs. % 000000
 Observed Cond % 000000
 Obs. Cond. Code
 Combination A
 Comb A Ht/AC
 Unfin Low/Level
 Full Basement F Full Baseme
 # Of Bedrooms 03 Three Bedro
 Sq.Ft.Grđ Area 1713

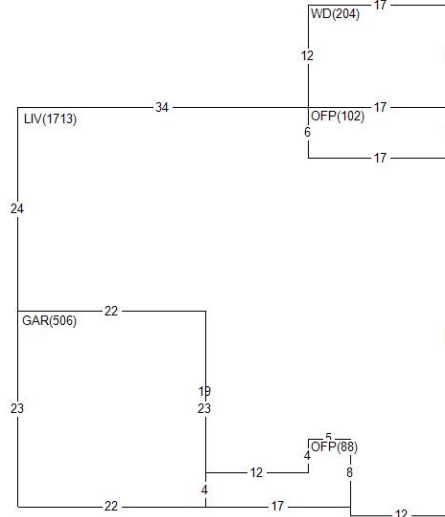

Land Value 26,760
 Misc Value 41,770
 Bldg Value 152,020
 Total Value 220,550
 Value By CAMA

RCN 155,123
 Pct Good 0.9800
 Obsol/Observed 0.0000
 Building Value 152,020

DOCUMENT #	DATE	QS	SALE PRICE
397534	0818	U	
365960	0613	Q	24,000

PERMIT NO	TYPE	DATE	AMOUNT
	00	1118	
	10	0818	
R2-13-04	01	0813	

Appraiser KS K. Sondag
 Apr Date 07/20/22
 Use Code 0040 Imp Res
 NBHD 62000.10 VLMYR 1.0 STORY
 L100 M100 B118

AREA	FLAT	EFF% E/AREA	ACT% A/AREA	EA/AA HEATED
LIV	1713	1.00	1713	1713
GAR	506	1.00	506	506
OFP	190	1.00	190	190
WD	204	1.00	204	204
PTO	818	1.00	818	818
CONDR	1054	1.00	1054	1054
POOL	512	1.00	512	512
SHED	144	1.00	144	144

MISC BLDG CODE	DESC	LENGTH	WIDTH	UNITS	ADJ PRICE	EYB DT PCT	ADJUSTMENT	VALUE
1 1 OFP	Open Frame Porch	.00	.00	88.00	28.43	2014 A 2.00	1.00	2,450
2 1 OFP	Open Frame Porch	6.00	17.00	102.00	26.86	2014 A 2.00	1.00	2,690
3 1 PTO	Concrete Patio	6.00	17.00	102.00	3.65	2014 A 2.00	1.00	370
4 1 WD	Wood Deck	12.00	17.00	204.00	19.35	2014 A 2.00	1.00	3,870
5 1 DORM	Dormer	.00	.00	1.00	1850.00	2014 OC 0.00	1.00	1,850
6 1 CONDR	Concrete Drivewa	31.00	34.00	1054.00	3.65	2014 A 2.00	1.00	3,770

LAND LUSE DESC	ZONING	UNITS TP	PRICE	ADJUSTMENT	CODE/FACTOR	VALUE
1 6200 VALMEYER	VR1	1.00 ST	26760.00	TW	1.00 .00 .00	26,760

Req By: KRIS_K
 ERIN R ROEVER &
 JONATHAN STOUT JR
 507 CLIFF VIEW PLACE

			VALMEYER		IL 62295						
			Site Address: 000507		CLIFF VIEW		PL				
MISC	BLDG CODE	DESC	LENGTH	WIDTH	UNITS	ADJ PRICE	EYB DT	PCT	ADJUSTMENT	VALUE	
7	1 BRVEN	Brick Veneer	.00	.00	256.00	14.65	2014 A	2.00	1.00	3,680	
8	1 POOLVNL	Vinyl Ln Res Poo	32.00	16.00	512.00	32.98	2018 A	1.00	1.00	16,720	
9	1 PTO	Concrete Patio	.00	.00	716.00	3.65	2018 A	1.00	1.00	2,590	
10	1 SHED	Frame Shed	12.00	12.00	144.00	26.53	2018 A	1.00	1.00	3,780	