

PART SE NW

WATERLOO IL 62298
Site Address: 002160 STATE ROUTE 156

BLDG # 1
 Style/Stories 1.5 1 1/2 Story
 Quality/Design C C-Average
 Building Use 0100 Single Fami
 Exterior Wall M Masonry 1.5
 WALL % 100 100%
 Exterior Wall 1
 WALL 1% 000 N/A
 Crawl Sp. Adj
 Slab Adjustment
 Basement
 Combination M1 Masonry/1.0
 Attic Area
 Heat/AC Adj AC Central Air
 Comb Ht/AC Adj AC1 Cent AC Cmb
 Fireplace 00 N/A
 Extra Fireplace 00 N/A
 Res Fixtures 0007 07 Fixtures
 Garage M Masonry Gar
 Integral Garage
 Remodeling Adj 03 Partial Upd
 Actual Year Blt 1870
 Effect Year Blt 1870
 Cond/Desir/Util A Res CDU - A
 Township Multpl 09 TOWNSHIP #0
 Funct. Obs. %
 Economic Obs. %
 Observed Cond %
 Obs. Cond. Code
 Combination A
 Comb A Ht/AC
 Unfin Low/Level
 Full Basement F Full Baseme
 # Of Bedrooms 03 Three Bedro
 Sq.Ft.Grd Area 2224

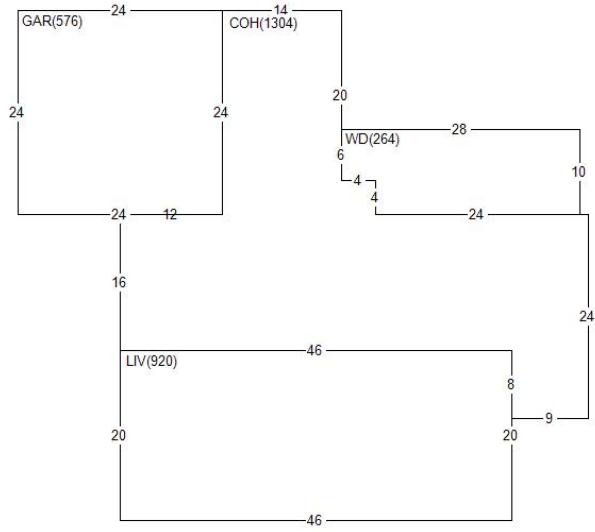

Land Value 20,920
 Misc Value 3,680
 Bldg Value 170,680
 Total Value 195,280
 Value By CAMA

RCN 310,318
 Pct Good 0.5500
 Obsol/Observed 0.0000
 Building Value 170,680

DOCUMENT #	DATE	QS	SALE PRICE
403296	0819	U	
	0890	Q	65,000

PERMIT NO	TYPE	DATE	AMOUNT
9696	04	1199	

Appraiser KS K. Sondag
 Appr Date 08/04/22
 Use Code 0040 Imp Res
 NBHD 1000.51 9/10 1.5 PR/1940
 L100 M100 B153

	AREA	FLAT	EFF% E/AREA	ACT% A/AREA	EA/AA	HEATED
LIV	920	1.00	920	1.00	920	920
COH	1304	1.00	1304	1.00	1304	1304
WD	264	1.00	264	1.00	264	264
GAR	576	1.00	576	1.00	576	576

MISC BLDG CODE	DESC	LENGTH	WIDTH	UNITS	ADJ PRICE	EYB DT PCT	ADJUSTMENT	VALUE
1 1 WD	Wood Deck	.00	.00	264.00	19.35	2000 P 28.00	1.00	3,680

LAND LUSE DESC	ZONING	UNITS TP	PRICE	ADJUSTMENT CODE/FACTOR	VALUE
1 CH County Road Cat.	MA1	.51 R	41013.07	.00 .00 .00 TW 1.00	20,920