

LOT 166 & PART LOT 165
NEW VALMEYER PHASE 3

VALMEYER IL 62295
Site Address: 000108 HILLCREST CT

BLDG # 1
 Style/Stories 2.0 2 Story
 Quality/Design C C-Average
 Building Use 0110 Single Fam.
 Exterior Wall M Masonry 2.0
 WALL % 100 100%
 Exterior Wall 1
 WALL 1% 000 N/A
 Crawl Sp. Adj
 Slab Adjustment
 Basement
 Combination M1 Masonry/1.0
 Attic Area FA Finished
 Heat/AC Adj AC Central Air
 Comb Ht/AC Adj AC1 Cent AC Cmb
 Fireplace 03 C-Fireplace
 Extra Fireplace 00 N/A
 Res Fixtures 0016 16 Fixtures
 Garage M Masonry Gar
 Integral Garage
 Remodeling Adj 01 No Remodeli
 Actual Year Blt 1994
 Effect Year Blt 1994
 Cond/Desir/Util A Res CDU - A
 Township Multpl 09 TOWNSHIP #0
 Funct. Obs. % 000000
 Economic Obs. % 000000
 Observed Cond % 000000
 Obs. Cond. Code
 Combination A
 Comb A Ht/AC
 Unfin Low/Level
 Full Basement F Full Baseme
 # Of Bedrooms 03 Three Bedro
 Sq.Ft.Grd Area 2717

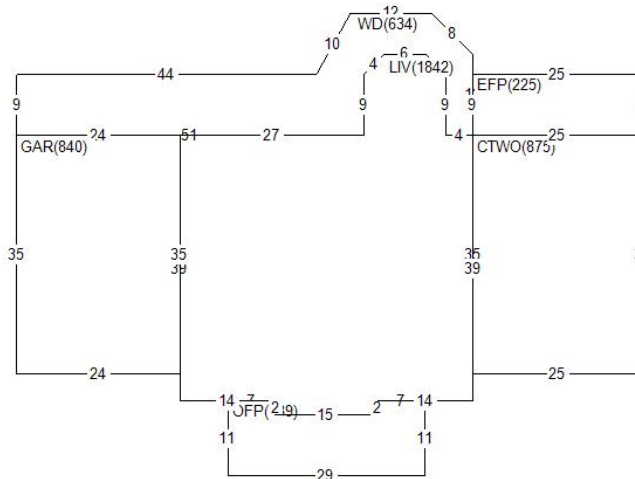

Land Value 26,760
 Misc Value 55,980
 Bldg Value 253,630
 Total Value 336,370
 Value By CAMA

RCN 309,309
 Pct Good 0.8200
 Obsol/Observed 0.0000
 Building Value 253,630

DOCUMENT #	DATE	QS	SALE PRICE
0296	U		
0994	U		27,168

PERMIT NO	TYPE	DATE	AMOUNT
R1-94-02	01	0994	

Appraiser KS K. Sondag
 Appr Date 07/20/22
 Use Code 0040 Imp Res
 NBHD 62000.20 VLMYR 2.0 STORY
 L100 M100 B094

AREA	FLAT	EFF% E/AREA	ACT% A/AREA	EA/AA HEATED
PTO	635	1.00	635 1.00	635 635
CONDR	3504	1.00	3504 1.00	3504 3504
FA	504	1.00	504 1.00	504 504
OFFP	514	1.00	514 1.00	514 514
WD	634	1.00	634 1.00	634 634
CTWO	875	1.00	875 1.00	875 875
EFP	225	1.00	225 1.00	225 225
LIV	1842	1.00	1842 1.00	1842 1842 1842
GAR	840	1.00	840 1.00	840 840

MISC BLDG CODE	DESC	LENGTH	WIDTH	UNITS	ADJ PRICE	EYB DT PCT	ADJUSTMENT	VALUE
1	1 OFFP	Open Frame Porch	.00	.00	289.00	23.04 1994 A 18.00	1.00	5,460
2	1 PTO	Concrete Patio	.00	.00	634.00	3.65 1994 A 18.00	1.00	1,900
3	1 EFP	Enclosed Fr. Por	9.00	25.00	225.00	38.95 1994 A 18.00	1.00	7,190
4	1 WD	Wood Deck	.00	.00	634.00	19.35 1994 A 18.00	1.00	10,060
5	1 CONDR	Concrete Drivewa	.00	.00	3504.00	3.65 1994 F 26.00	1.00	9,470
6	1 DORM	Dormer	.00	.00	1.00	1850.00 1994 OD 0.00	1.00	1,850
LAND LUSE DESC	ZONING	UNITS TP	PRICE	ADJUSTMENT	CODE/FACTOR	ADJUSTMENT	VALUE	
1 6200 VALMEYER	VR1	1.00 ST	26760.00	.00	.00	.00 TW 1.00	26,760	

MISC	BLDG CODE	DESC	Site Address:	VALMEYER	HILLCREST	IL 62295	CT	ADJ PRICE	EYB DT	PCT	ADJUSTMENT	VALUE
			LENGTH	WIDTH	UNITS							
7	1 OFP	Open Frame Porch	9.00	25.00	225.00			23.28	1994 A	18.00	1.00	4,300
8	1 BRVEN	Brick Veneer	.00	.00	1311.00			14.65	1994 A	18.00	1.00	15,750