

LOT 191 AMENDED PHASE 3
RESUBDIVISION NEW VALMEYER

VALMEYER IL 62295
Site Address: 000117 W WOODLAND RIDGE

BLDG # 1
 Style/Stories 1.0 One Story
 Quality/Design C C-Average
 Building Use 0100 Single Fami
 Exterior Wall F Frame
 WALL % 100 100%
 Exterior Wall 1
 WALL 1% 000 N/A
 Crawl Sp. Adj
 Slab Adjustment
 Basement
 Combination
 Attic Area
 Heat/AC Adj AC Central Air
 Comb Ht/AC Adj
 Fireplace 00 N/A
 Extra Fireplace 00 N/A
 Res Fixtures 0009 09 Fixtures
 Garage F Frame Garag
 Integral Garage
 Remodeling Adj 01 No Remodeli
 Actual Year Blt 2004
 Effect Year Blt 2004
 Cond/Desir/Util A Res CDU - A
 Township Multpl 09 TOWNSHIP #0
 Funct. Obs. %
 Economic Obs. %
 Observed Cond %
 Obs. Cond. Code
 Combination A
 Comb A Ht/AC
 Unfin Low/Level
 Full Basement F Full Baseme
 # Of Bedrooms 03 Three Bedro
 Sq.Ft.Grnd Area 1522

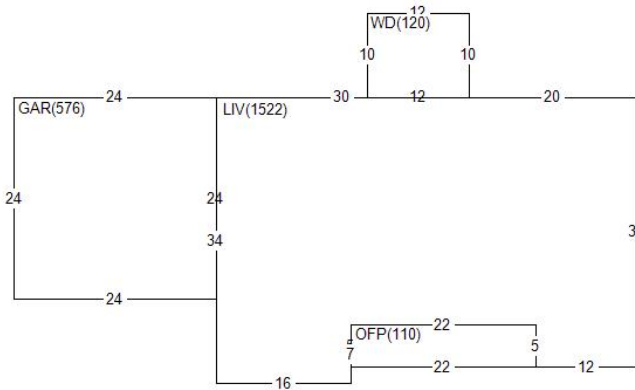

Land Value 26,760
 Misc Value 14,540
 Bldg Value 134,190
 Total Value 175,490
 Value By CAMA

RCN 147,465
 Pct Good 0.9100
 Obsol/Observed 0.0000
 Building Value 134,190

DOCUMENT #	DATE	QS	SALE PRICE
377694	0615	Q	145,500
330358	0309	U	
292532	1104	Q	167,500
PERMIT NO	TYPE	DATE	AMOUNT
R1-04-27	01	0604	

Appraiser KS K. Sondag
 Appr Date 07/21/22
 Use Code 0040 Imp Res
 NBHD 62000.10 VLMYR 1.0 STORY
 L100 M100 B118

AREA	FLAT	EFF% E/AREA	ACT% A/AREA	EA/AA HEATED
OFP	110	1.00	110	110
GAR	576	1.00	576	576
WD	120	1.00	120	120
LIV	1522	1.00	1522	1522
PTO	96	1.00	96	96
CONDR	984	1.00	984	984

MISC BLDG CODE	DESC	LENGTH	WIDTH	UNITS	ADJ PRICE	EYB DT PCT	ADJUSTMENT	VALUE
1 1 BRVEN	Brick Veneer	.00	.00	466.00	14.65	2004 A 9.00	1.00	6,210
2 1 CONDR	Concrete Drivewa	41.00	24.00	984.00	3.65	2004 A 9.00	1.00	3,270
3 1 OFP	Open Frame Porch	5.00	22.00	110.00	26.28	2004 A 9.00	1.00	2,630
4 1 WD	Wood Deck	10.00	12.00	120.00	19.35	2004 A 9.00	1.00	2,110
5 1 PTO	Concrete Patio	8.00	12.00	96.00	3.65	2004 A 9.00	1.00	320

LAND LUSE DESC	ZONING	UNITS TP	PRICE	ADJUSTMENT	CODE/FACTOR	VALUE
1 6200 VALMEYER	VR1	1.00 ST	26760.00	TW 1.00	.00 .00 .00	26,760