

LOT 146 NEW VALMEYER PHASE 2

VALMEYER IL 62295
Site Address: 000132 W HUNTERS RIDGE

BLDG # 1
 Style/Stories 1.0 One Story
 Quality/Design C C-Average
 Building Use 0100 Single Fami
 Exterior Wall F Frame
 WALL % 100 100%
 Exterior Wall 1
 WALL 1% 000 N/A
 Crawl Sp. Adj
 Slab Adjustment
 Basement
 Combination
 Attic Area
 Heat/AC Adj AC Central Air
 Comb Ht/AC Adj
 Fireplace 00 N/A
 Extra Fireplace 00 N/A
 Res Fixtures 0011 11 Fixtures
 Garage F Frame Garag
 Integral Garage
 Remodeling Adj 01 No Remodeli
 Actual Year Blt 2004
 Effect Year Blt 2004
 Cond/Desir/Util A
 Township Multpl 09 TOWNSHIP #0
 Funct. Obs. %
 Economic Obs. %
 Observed Cond %
 Obs. Cond. Code
 Combination A
 Comb A Ht/AC
 Unfin Low/Level
 Full Basement F Full Baseme
 # Of Bedrooms 03 Three Bedro
 Sq.Ft.Grđ Area 1423

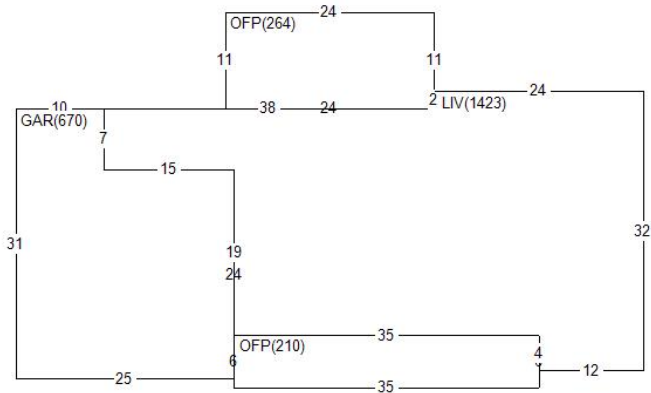

Land Value 26,760
 Misc Value 12,950
 Bldg Value 134,660
 Total Value 174,370
 Value By CAMA

RCN 147,973
 Pct Good 0.9100
 Obsol/Observed 0.0000
 Building Value 134,660

DOCUMENT #	DATE	QS	SALE PRICE
283088	1203	Q	22,500
	0402	Q	17,420

PERMIT NO	TYPE	DATE	AMOUNT
R1-04-05	01	0304	

Appraiser KS K. Sondag
 Appr Date 07/25/22
 Use Code 0040 Imp Res
 NBHD 62000.10 VLMYR 1.0 STORY
 L100 M100 B118

AREA	FLAT	EFF%	E/AREA	ACT%	A/AREA	EA/AA	HEATED
OFF	474	1.00	474	1.00	474	474	
GAR	670	1.00	670	1.00	670	670	
LIV	1423	1.00	1423	1.00	1423	1423	1423
CONDR	782	1.00	782	1.00	782	782	

MISC BLDG CODE	DESC	LENGTH	WIDTH	UNITS	ADJ PRICE	EYB DT PCT	ADJUSTMENT	VALUE
1 1 OFF	Open Frame Porch	6.00	35.00	210.00	22.96	2004 A 9.00	1.00	4,390
2 1 CONDR	Concrete Drivewa	34.00	23.00	782.00	3.65	2004 A 9.00	1.00	2,600
3 1 OFF	Open Frame Porch	11.00	24.00	264.00	23.53	2011 A 4.00	1.00	5,960

LAND LUSE DESC	ZONING	UNITS TP	PRICE	ADJUSTMENT	CODE/FACTOR	VALUE
1 6200 VALMEYER	VR1	1.00 ST	26760.00	TW 1.00	.00 .00	26,760