

LOT 153 NEW VALMEYER PHASE 2

VALMEYER IL 62295
Site Address: 000113 W HUNTERS RIDGE

BLDG # 1
 Style/Stories 1.0 One Story
 Quality/Design C C-Average
 Building Use 0100 Single Fami
 Exterior Wall F Frame
 WALL % 100 100%
 Exterior Wall 1
 WALL 1% 000 N/A
 Crawl Sp. Adj
 Slab Adjustment
 Basement
 Combination
 Attic Area
 Heat/AC Adj AC Central Air
 Comb Ht/AC Adj
 Fireplace 00 N/A
 Extra Fireplace 00 N/A
 Res Fixtures 0009 09 Fixtures
 Garage F Frame Garag
 Integral Garage
 Remodeling Adj 01 No Remodeli
 Actual Year Blt 1999
 Effect Year Blt 1999
 Cond/Desir/Util A Res CDU - A
 Township Multpl 09 TOWNSHIP #0
 Funct. Obs. % 000000
 Economic Obs. % 000000
 Observed Cond % 000000
 Obs. Cond. Code
 Combination A
 Comb A Ht/AC
 Unfin Low/Level
 Full Basement F Full Baseme
 # Of Bedrooms 03 Three Bedro
 Sq.Ft.Grnd Area 1274

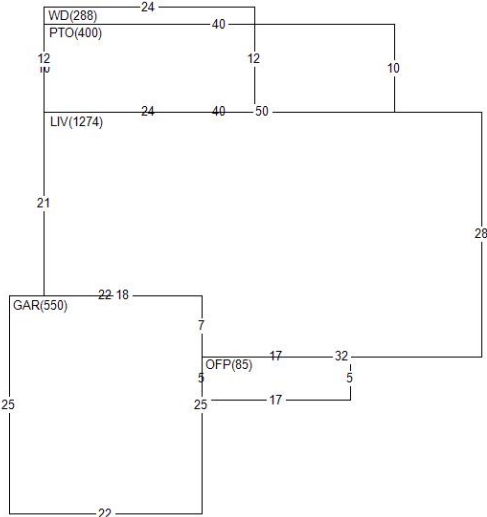

Land Value 26,760
 Misc Value 13,690
 Bldg Value 115,280
 Total Value 155,730
 Value By CAMA

RCN 132,500
 Pct Good 0.8700
 Obsol/Observed 0.0000
 Building Value 115,280

DOCUMENT #	DATE	QS	SALE PRICE
413959	0121	U	
	1099	U	
	1094	U	5,400

PERMIT NO	TYPE	DATE	AMOUNT
R1-99-14	00	1299	
R1-99-14	01	0999	

Appraiser KS K. Sondag
 Appr Date 07/25/22
 Use Code 0040 Imp Res
 NBHD 62000.10 VLMYR 1.0 STORY
 L100 M100 B118

AREA	FLAT	EFF%	E/AREA	ACT%	A/AREA	EA/AA	HEATED
OFFP	85	1.00	85	1.00	85	85	
GAR	550	1.00	550	1.00	550	550	
PTO	400	1.00	400	1.00	400	400	
WD	288	1.00	288	1.00	288	288	
LIV	1274	1.00	1274	1.00	1274	1274	1274
CONDR	525	1.00	525	1.00	525	525	

MISC BLDG CODE	DESC	LENGTH	WIDTH	UNITS	ADJ PRICE	EYB DT	PCT	ADJUSTMENT	VALUE
1 1 CONDR	Concrete Drivewa	25.00	21.00	525.00	3.65	1999 A	13.00	1.00	1,670
2 1 OFFP	Open Frame Porch	5.00	17.00	85.00	28.79	1999 A	13.00	1.00	2,130
3 1 PTO	Concrete Patio	10.00	40.00	400.00	3.65	1999 A	13.00	1.00	1,270
4 1 WD	Wood Deck	12.00	24.00	288.00	19.35	1999 A	13.00	1.00	4,850
5 1 BRVEN	Brick Veneer	37.00	8.00	296.00	14.65	1999 A	13.00	1.00	3,770

LAND LUSE DESC	ZONING	UNITS TP	PRICE	ADJUSTMENT	CODE/FACTOR	VALUE
1 6200 VALMEYER	VR1	1.00 ST	26760.00	.00	.00 TW 1.00	26,760